

Low voltage

Acti 9

the efficiency you deserve

Catalogue
2013



Acti 9

The safest, simplest and most efficient system for power distribution solutions

Protection devices

- > Miniature circuit breaker
- > Residual current circuit breaker
- > Vigi™ residual current devices
- > Surge arrester

Protection monitoring and supervision

- > Indication and tripping auxiliaries
- > Remote control auxiliaries
- > Automatic recloser auxiliaries



Safer

VisiSafe and Class 2 give complete safety for the life of your installation



More efficient

VisiTrip, super immunisation, and automatic reclosers increase continuity of service and enhance reliability

Control and monitoring

- > Contactors
- > Impulse relays
- > Integrated control circuit breaker
- > Light indicators
- > Push-buttons and selector switches
- > Kilowatt hour meters
- > Communicating architecture

Installation system

- > Isobar
- > IP20B terminals
- > Splitter block
- > Full range of mounting and wiring accessories
- > Multiclip



Simpler and smarter

Two certifications for one product, 100 per cent MCB and RCD coordination and easy ordering and design



Monitor and adjust specific loads

Manage loads, reduce operating or project costs and accurately plan maintenance

'You can tell it's a high quality product
when you hold it in your hands'



A better use of energy, from start to finish

Acti 9 helps you meet developing energy efficiency and environmental certifications or requirements, now and in the future. It minimises impact from the design stage, through the installation's lifetime of use and eventual recycling. Through both design and technology, Acti 9 provides you with the key combination of less impact and more efficiency that is necessary for the environment today.

100%

recyclable and recoverable materials, RoHS compliant and REACH

Acti 9 is your safe, efficient and simple choice for low-voltage modular systems

5 generations

of industry experience and 22 new patents make Acti 9 the new reference in low-voltage modular systems

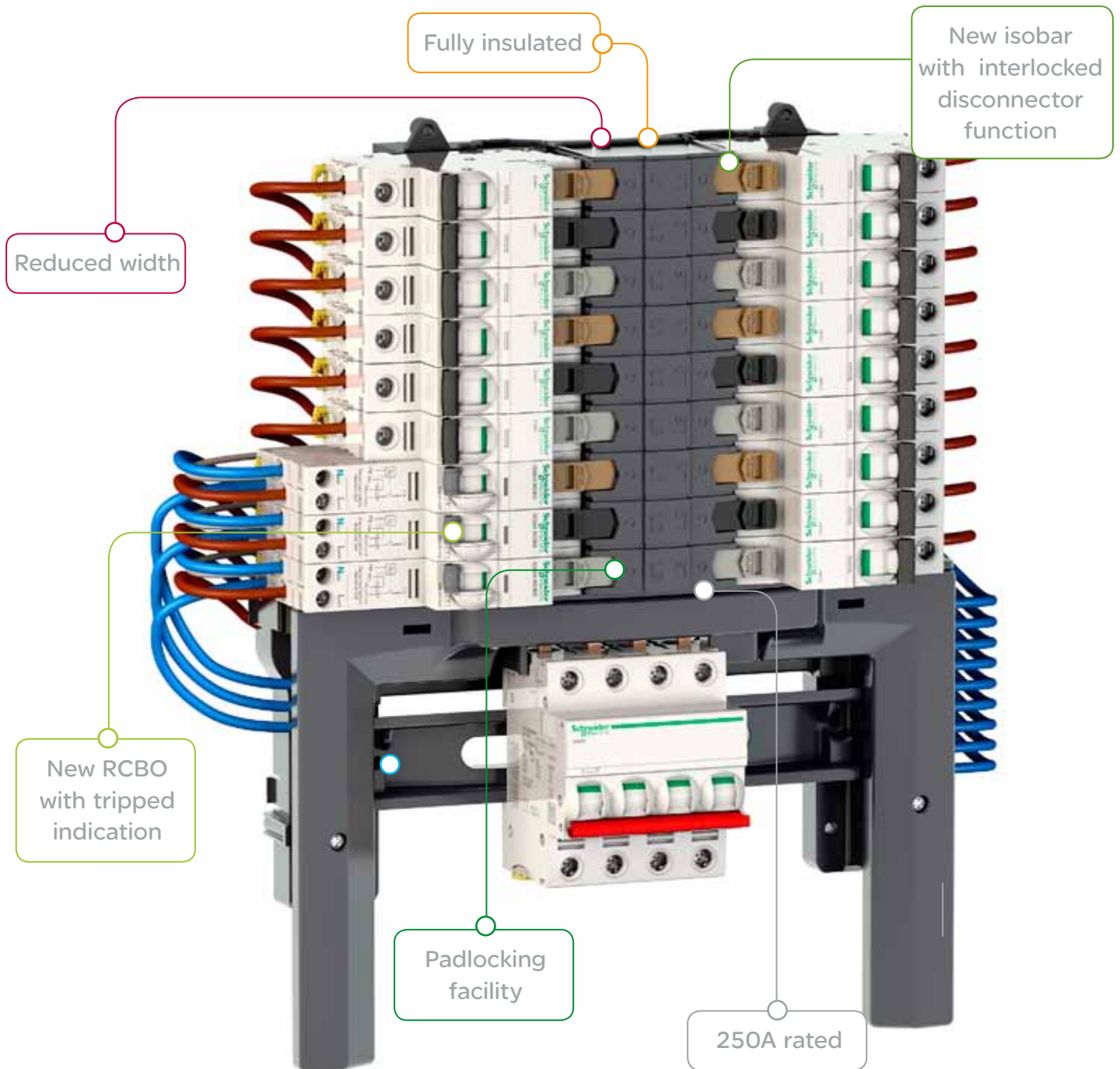

> Acti 9

'In short, I optimise my own energy'



The new core modular system which makes your power distribution installation safer, simpler and more efficient

We leveraged five generations of low-voltage expertise to design a precise, high-quality modular system without compromise. Acti 9™ offers the fastest, most flexible installation experience and completely eliminates safety concerns during maintenance and operation. Engineered to adapt to the most challenging networks and environments whilst remaining cost-effective over time, it is the most flexible, coordinated, comprehensive and innovative range of low-voltage modular devices available.

A new generation of distribution boards complements the Acti9 offer, based on the design of the proven Isobar range with added features for increased safety and measurement. Acti9 Isobar incorporates more cable space and an interlock to prevent inadvertent operation of the Isobar switch disconnecter unless an outgoing device is installed.



Acti 9 gives you safety, simplicity and efficiency for the life span of your installation



High-quality modular system without compromise



Acti 9: The **fifth** generation of modular systems

Safe

Safest operation guaranteed even in the most demanding environments

100%

safe for installers and users in the most severe environments



Best choice for industrial and commercial buildings



Designed for safety, even in the most demanding environments

Safety matters most and Acti 9 Isobar gives you, your customers and their installations the highest level of protection available. It guarantees 100 per cent safe operation and maintenance for you and your customers. Its international certifications and numerous protection innovations allow Acti 9 to exceed even the most demanding requirements to give you total safety during maintenance, for the lifetime of your installation.

Comprehensive certification

 CEBEC	 VDE	 GOST
 AENOR	 IMQ	 CCC (China)
 IRAM	 NF	 SABS

Delivers complete industry-approved protection

Acti 9 is fully tested, approved and certified by national and international third parties. It guarantees that your installation is safe and compliant with all relevant safety standards and demonstrates to your customers that you use industry-approved materials and best practices.

"I have no worries about the safety of the electrical installation, the buildings and everyone inside"

Guarantees total safety during maintenance



VisiSafe

VisiSafe™ guarantees the downstream circuit is always safe, regardless of overvoltage conditions, wear or operator experience, even in the most demanding environments.

The green strip indicates the safe position of contacts. Unique safety features:

- Highest impulse voltage withstand: $U_{imp} = 6 \text{ kV}$
- Guarantees longer equipment service life despite overvoltage conditions
- Highest pollution resistance among modular devices: Pollution Degree level 3
- A true 'all-terrain' product ideally suited for all environments
- Leading edge insulation voltage: 500 V
- Complete safety for operators manoeuvring the operating handle

Available only from Schneider Electric

Promises absolute protection against electric shocks



Available only from Schneider Electric

Class 2 front face

Acti 9 circuit breaker is the only device available with this level of safety. Clearances between breaker surfaces and internal parts are more than double the industry standard. It guarantees risk-free handling during the life of the installation, regardless of environment or operator experience.

Safer on site

Guarantees long life service



Fast closing mechanism

Fast closure of all Acti 9 MCBs and RCCBs limits wear and reduces voltage drops, helping to prevent premature equipment aging and overheating.

Provides zero-risk lockdown



Integrated padlocking

The integrated padlock guarantees protection and safety of Acti 9 remote control devices, preventing toggle movement and inadvertent or unauthorised access.



Integrated interlock does not allow the Iso-bar switch disconnectors to be operated without an outgoing device fitted

Simple and smart



The right solution for every application

Acti 9 simplifies final distribution operations in buildings and industrial facilities, giving you the right solution with the right technical characteristics for every application. As new installation standards emerge or building requirements are modified, Acti 9 can easily scale to meet your needs. It's a flexible, open system with all-in-one, integrated components which can communicate with any building management system.

"Simple to choose, easy to design,
install and upgrade"

Easy to design and choose

Meets two certifications

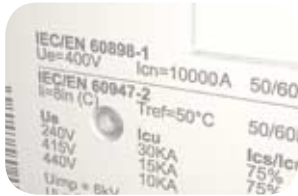

Acti 9 miniature circuit breakers comply with IEC/EN 947 (industrial) and IEC/EN 898 (tertiary) standards – two certifications in one product – making it perfect for commercial and industrial applications.

30%

of switchboards are modified at design, cabling or commissioning stages, increasing project start-up times

Supports intuitive ordering and design



Meaningful part numbers mean no mistakes and no doubts when ordering or designing. Get the product type, poles and rating in one glance.

A9XXX225 = 2P, 25A

Guarantees 100 per cent coordination



100 per cent coordination between RCDs and MCBs means no more searching through technical guides or coordination tables. In addition, in the Reflex™ iC60, protection and control are a unique all-in-one concept fully covered by the manufacturer's warranty.

Reflex iC60: the all-in-one concept integrated control circuit breaker



Available only from
Schneider Electric



Reflex iC60 combines the functions of an MCB and contactor. Designed to evolve and adapt with the dynamic requirements of tertiary and industrial lighting control applications, it easily communicates with PLCs and BMS systems without the need for add-ons, retrofits or extras. Everything you need is included.



Efficient

The system which streamlines your operations workflow



Designed to minimise downtime and avoid nuisance trips

With features like VisiTrip, super immunisation of RCDs (SI) and ARA automatic recloser auxiliary, Acti 9 system allows easier building management, reduces downtime and makes your business more competitive limiting intervention costs on distant infrastructures sites.

Less downtime, more continuity of service

VisiTrip minimises downtime and reduces repair times Identify faults in one glance and you will easily see the operating status of your network. VisiTrip™ indicates only the faulty outgoing, allowing fast diagnosis, resolution and reclosing loads for easier building management and reduced downtime.



Prevents unnecessary trips

Super immunisation (SI) of the RCDs guarantees the highest continuity of service and electrical immunity, especially where switchgear contends with electromagnetic or chemical interference. It also meets the high continuity of service requirements in all critical power applications (hospitals, data centres, telecoms and tunnels).

No need for on-site intervention



Acti 9 introduces a new automatic recloser auxiliary (ARA iC60) designed to limit the cost of intervention on faraway infrastructure sites. There's no need to have permanent on-site teams responding to transient faults, limiting distant site intervention costs.

"Everything is simpler with Acti 9. Whatever the application, I have no second thoughts"

Easy to operate

Provides greater readability



Its ergonomic interface allows specific color coding for padlocking devices. The N indicator is easily readable for speed of servicing. Acti 9 label maker gives your installation a professional appearance.

Safe and secure connections



Provides secure connections with quick, ergonomic and safe IP20B insulated terminal shutters.

Comes with tailored accessories



Acti 9 system includes a comprehensive list of accessories: easily installed padlock system, splitter block, rotary handle mount for switchboard doors, screw shields, sealable terminal shields, plug-in base, interpole barrier and clip-on markers.

Easy to upgrade

Adapts to your installation



It adapts to new requirements and simplifies evolution of the system.

Evolves with changing site requirements



Multiclip™ distribution system allows you to quickly add outgoing and balance phases. Multiclip offers screwless, safe connections.

100%

coordination between MCB and actuator

15%

time saved on design and installation

Acti 9

The safest, simplest and most efficient system for power distribution solutions



Acti 9 communication system

> Smart

- Centralise control, collect energy meter data with just a simple, ready-to-connect communication module
- Large diversity of data available to universal Modbus protocol

> Efficient

- One-click, prefabricated wiring for comprehensive communication between your distribution panel and any facility management system

> Safe

- Reliable, error-proof manufacturer guaranteed connections
- EMC tested for immunity, radiated and conducted safety

Acti 9 Smartlink: the heart of the system

Available only from
Schneider Electric

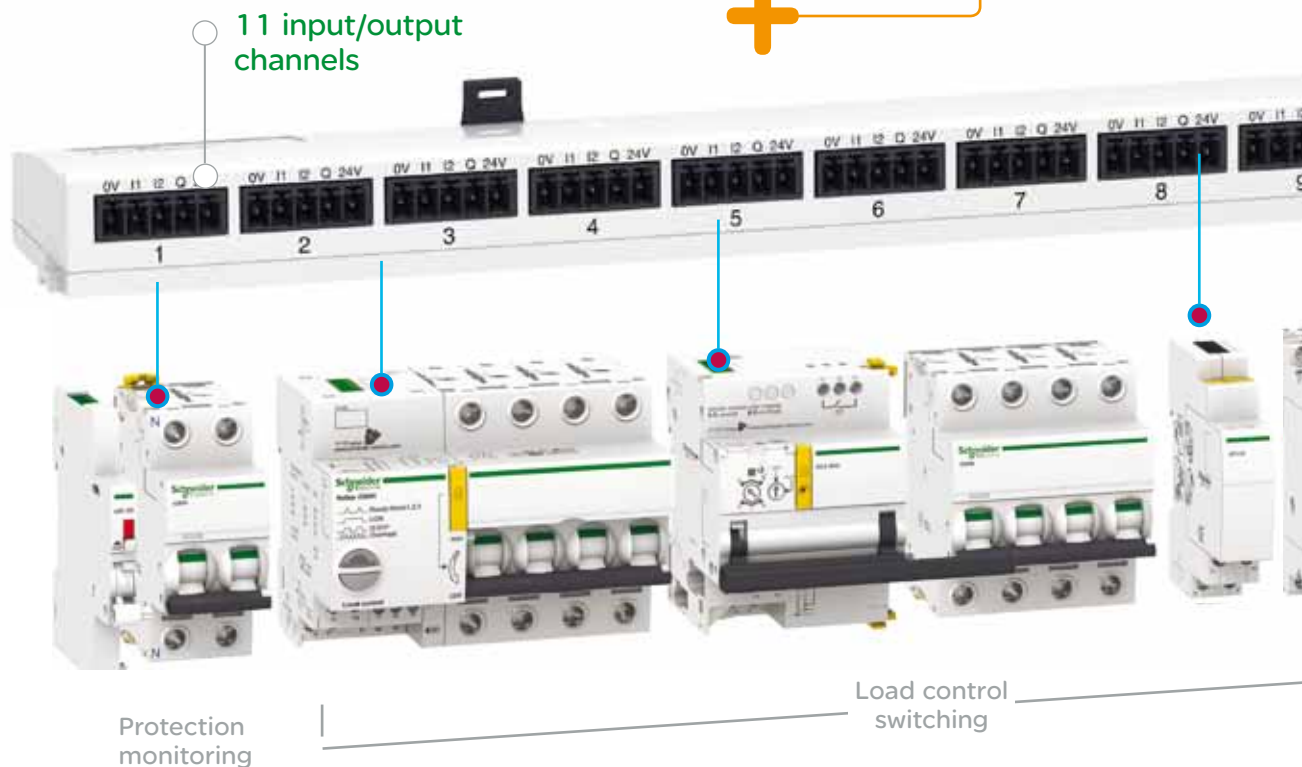

Meets the challenge of all your applications

Interior and exterior lighting, load monitoring and cost allocation

Ready to connect to any facility management solution

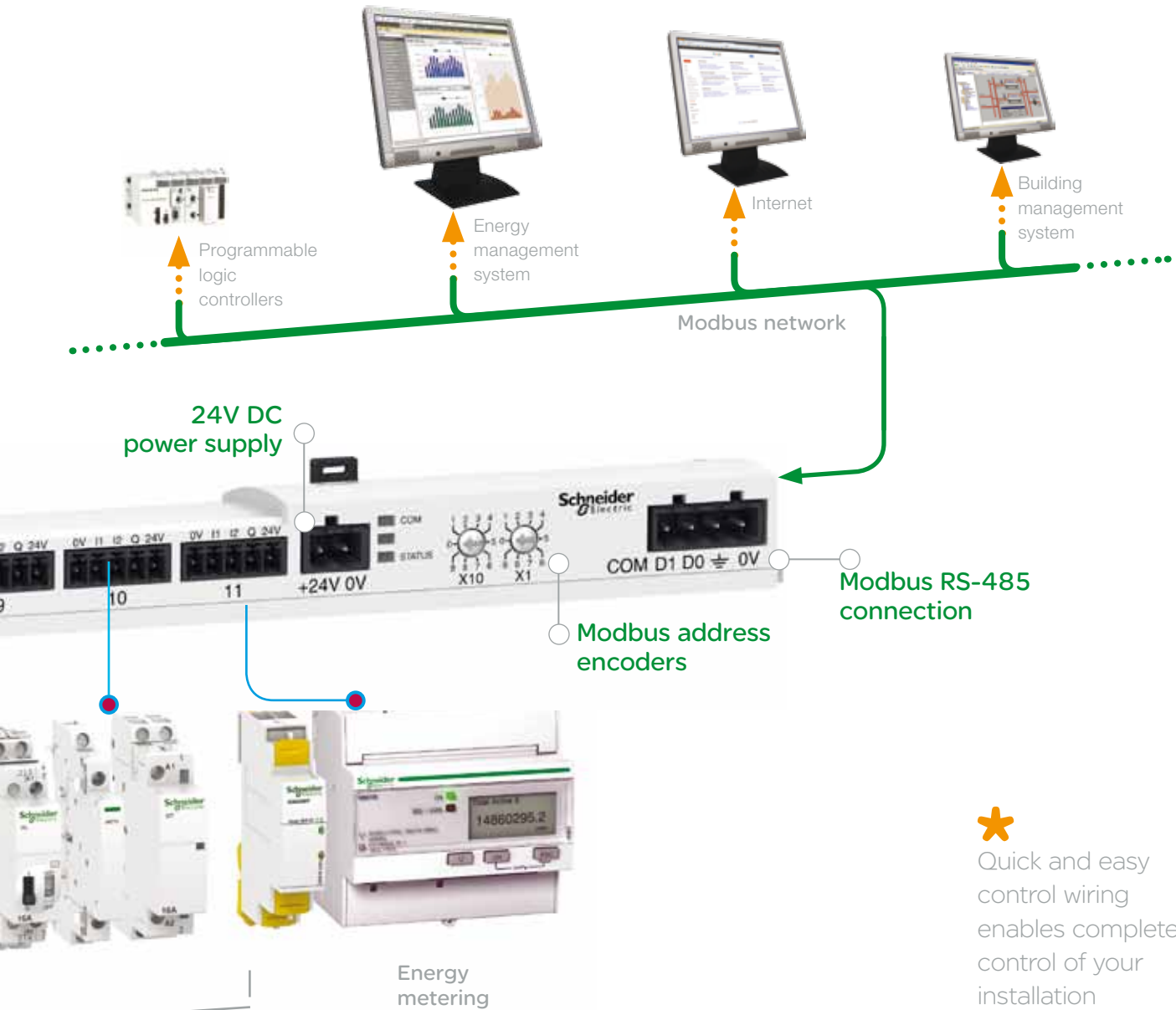

Monitor and adjust specific loads

Detailed load control, reduced downtime and accurately planned maintenance

> Acti 9

The safest, simplest and most efficient system for power distribution solutions

Circuit breakers

- 1 pole
- 2 poles
- 3 poles
- 4 poles

Electrical auxiliaries

Tripping, notification, indication and remote status indication

Installation system

IP20B terminals, splitter block, full range of mounting and wiring accessories, communicating architecture

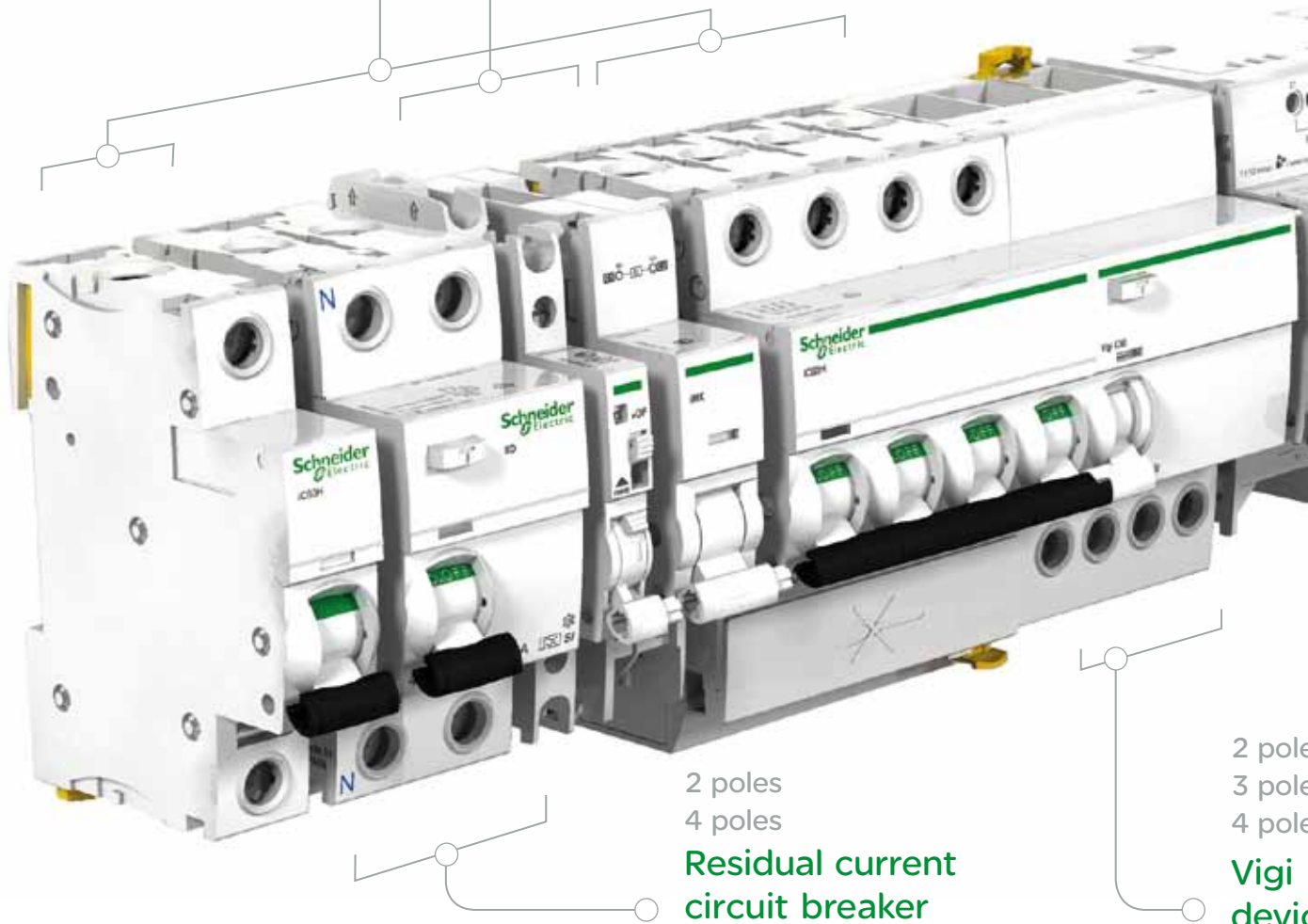

2 poles
4 poles
Residual current circuit breaker

2 poles
3 poles
4 poles
Vigi device

100%

safe for installers and users in the most severe environments

100%

coordination between MCB and actuator

100%

preventative maintenance

“When I install the Acti 9 I know I don’t
have to come back to the job”

ms

g
s,
ecture

Control

Contactors,
impulse relays,
indicator lights, pushbuttons,
kilowatt hour meters and
selector switches, etc.

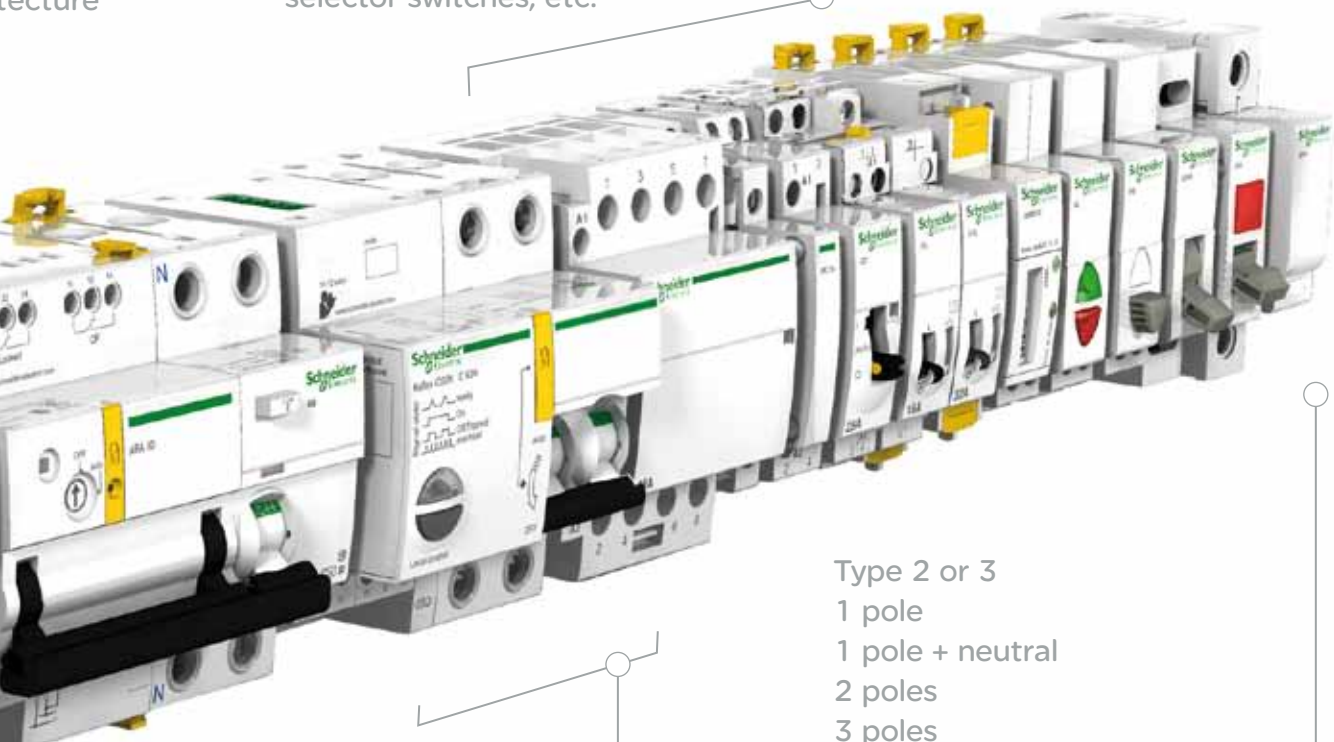

Automatic recloser auxiliaries

es
es
es
residual current
ce module

- Type 2 or 3
- 1 pole
- 1 pole + neutral
- 2 poles
- 3 poles
- 3 poles + neutral
- 4 poles

Surge arresters

- 2 poles
- 3 poles
- 4 poles

Integrated remote control circuit breaker

15%

time saved on
design and
installation

0%

down time



best choice for
industrial and
tertiary buildings

Technical characteristics

Circuit breakers

iC60, H

ICU (A) at 400V - IEC/EN 60898-1	10000
ICU (kA) at 415V - IEC/EN 60947-2	15
Type	1P, 1P+N, 2P, 3P, 4P
Rating (A)	0,5 to 63
Curves	B, C, D
Standards	IEC/BSEN 60947-2, 60898-1



Residual current devices

Vigi iC60

iC60 RCBO

RCD Type	AC, A, SI	A
Type	2P, 3P, 4P	1P + N
Rating (A)	25, 40, 63	6 to 45
Standards	IEC/EN 61009-1	BSEN 61009-1
Sensitivity (mA)	10, 30, 100, 300, 300 [S], 500, 500 [S], 1000 [S]	10, 30, 100



Connection between iC60 and iC60 Vigi

Residual current circuit breakers

iID

RCD Type	Asi, A, AC, B
Type	2P, 4P
Rating (A)	16 to 125
Standards	IEC/EN 61008-1
Sensitivity (mA)	10, 30, 100, 300, 300 [S], 500, 500 [S]



Electrical auxiliaries and mounting accessories



Combined iOF, iSD, iMN, iMX and iMSU electrical auxiliaries between iC60 circuit breakers and iID residual current circuit breakers, automatic recloser (ARA) and remote control auxiliaries (RCA)

Terminal shields, interpole barrier, screw shields, padlocking device, clip-on terminal markers and rotary handle

Surge arresters type 2 or 3

iPF, iPRD

Type	1P, 1P+N, 2P, 3P, 3P+N, 4P
I max (kA)	8, 20, 40, 65
Standards	IEC 61643-1, IEC 61643-11
Degree of protection	IP20/IP40



Integrated remote control MCBs

Reflex, iC60H

Curves	B, C, D
Type	2P, 3P, 4P
Rating (A)	10, 16, 25, 40
Standards	IEC 60947-2
Electrical endurance	30 000 cycles (AC1) 6,000 cycles (AC5 a/b) 50 000 cycles (AC21)



Control	iCT	iTL	iPB	iSSW	iIL	iEN, iEM
Function	Contactors	Impulse Relays	Push-buttons	Switches	Indicator Lights	Kilowatt hour meters
Type	1P, 2P 3P, 4P	1P, 2P, 3P, 4P	single double single + indicator light	1P, 2P, 3P, 4P	single double flashing light voltage presence	single phase three phases neutral
Rating (A)	16, 25, 40, 63,100	16 & 32	20	20 to 125		40 to 6000



Lighting, time and energy management

MIN	IH, IHP, ITM	IC	TH, THP	CDS
Silent electronic and electromechanical timers	Programmable and mechanical time switches	Standard and programmable twilight switches	Standard and weekly programmable thermostats	Single and three-phase load-shedders



Installation and wiring

Multiclip™ splitter block

Acti 9 Smartlink

Isobar

Rating (A)	80	--	250
Degree of protection	IP20	IP20	IP31



Ordering references

Acti9 Distribution boards	22
Introduction	22
A type	24
B type	28
Acti9 miniature circuit breakers	36
iC60H 1,2,3,4 pole Mcbs	36
iC60H single pole wide RCBO	40
iC60 Vigibloc	42
iC60 Auxiliaries	45
iC60 Accessories	52
Residual Current Circuit Breakers	56
iID RCCB	56
Technical	61
Dimensions	114

A type single phase boards

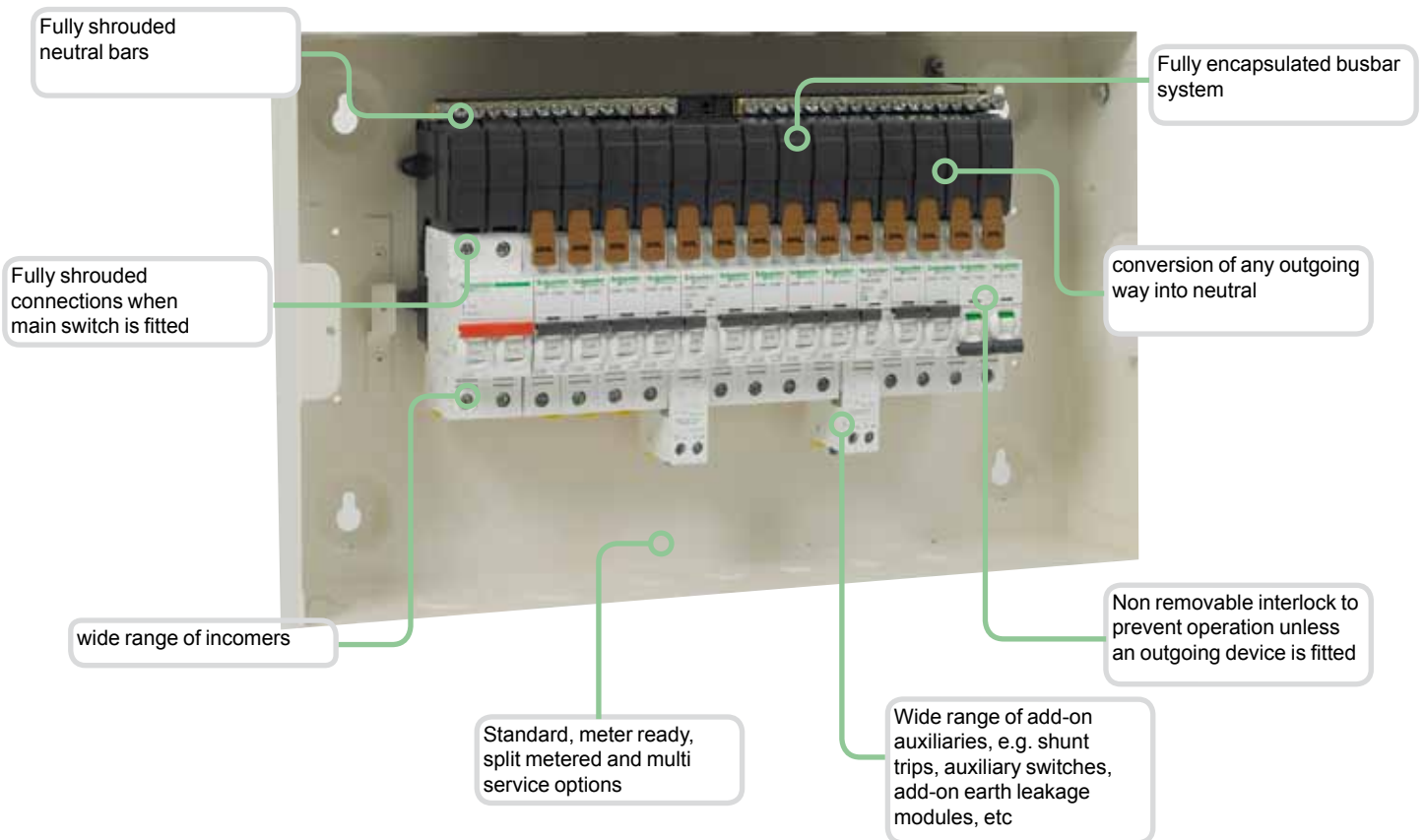

- Fully type tested conditional short circuit rating of 16kA to BS EN 61439-3
- High performance MCB 10kA BS EN 60898 15kA BS EN 60947-2 in B, C or D curve single and double pole
- 125A busbar rating
- Isobar disconnection to BS EN 60947-3 ensuring unused outgoing ways are isolated
- Option of switching outgoing neutral on all boards using distributed neutral kit
- Terminal block for feeding up to 100A
- Range of incomers: switch disconnectors, residual current devices, terminal blocks
- Single pole RCBO for new or retrofit maintaining device density
- Full range of device accessories and auxiliaries
- Knockouts for cable gland and conduit mixed to suit the installation needs without loss of space
- Split metering options

B Type 3 phase distribution

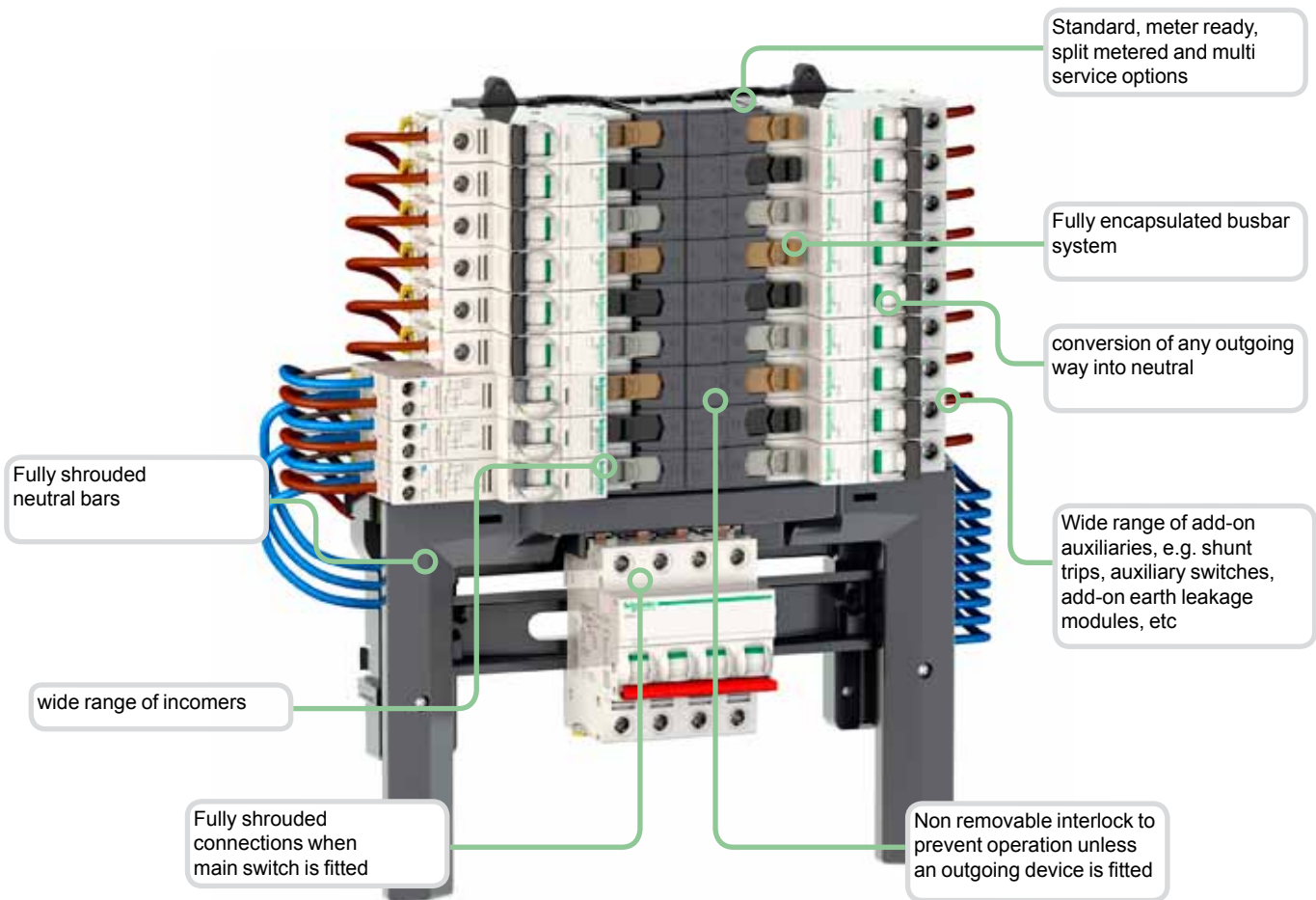

- Fully type tested conditional short circuit rating of 25kA to BS EN 61439-3
- High performance MCB 10kA BS EN 60898 15kA BS EN 60947-2 in B, C or D curve 1, 2, 3, 4 pole
- 250A busbar rating
- Isobar disconnection to BS EN 60947-3 ensuring unused outgoing ways are isolated
- Option of switching outgoing neutral on all boards using distributed neutral kit
- Terminal block for feeding up to 100A
- Range of incomers: switch disconnectors, residual current devices, terminal blocks, mccb
- Single pole RCBO for new or retrofit maintaining device density
- Full range of device accessories and auxiliaries
- Knockouts for cable gland and conduit mixed to suit the installation needs without loss of space
- Removable insulated pan assembly
- Fully shrouded neutral
- Split neutral bars
- Removable gland plates
- Optional metering, dual supply, surge protection and contactor on incoming
- Metered extension enclosures

Acti9 Isobar A type distribution boards

BS EN 61439-3

IEC 61439-3

- Acti9 Isobar is a complete range of single and 3 phase distribution boards for commercial and industrial applications
- Standard distribution boards up to 24 ways
- Multi service distribution boards up to 24 ways
- Dual incomer distribution boards up to 24 ways
- Split load distribution boards up to 24 ways
- Split metered distribution boards up to 20 ways
- Any outgoing way can be converted to switch the Neutral



Alternating current (AC) 50Hz		
withstand	110v	230/240v
conditional	25kA	25kA
unconditional	25kA/50mS	25kA/50mS
	17kA/200mS	17kA/200mS
Direct current (DC)		
	24v	48v
unconditional	25kA/50mS	25kA/50mS

Catalogue numbers

Acti9 Isobar Standard distribution boards busbar rating 125amp		
incomers not included	No of SP ways	No of DP ways
SEA9AN2	2	1
SEA9AN6	6	3
SEA9AN10	10	5
SEA9AN14	14	7
SEA9AN18	18	9
SEA9AN27	27	12

Acti9 Isobar Multi service distribution boards busbar rating 125amp		
incomers not included	No of SP ways	Useable DIN rail 9mm ways
SEA9AN1008MS	10	8
SEA9AN1016MS	10	16
SEA9AN1432MS	14	32
SEA9AN616MS	6	16
SEA9AN624MS	6	24

Acti9 Isobar Split load distribution boards busbar rating 125amp		
incomers not included	Unprotected way	Protected ways
SEA9AN106SL	10	6
SEA9AN610SL	6	10
SEA9AN66SL	6	6

Acti 9 Isobar
the safest distribution board

Acti9 Isobar A type distribution boards

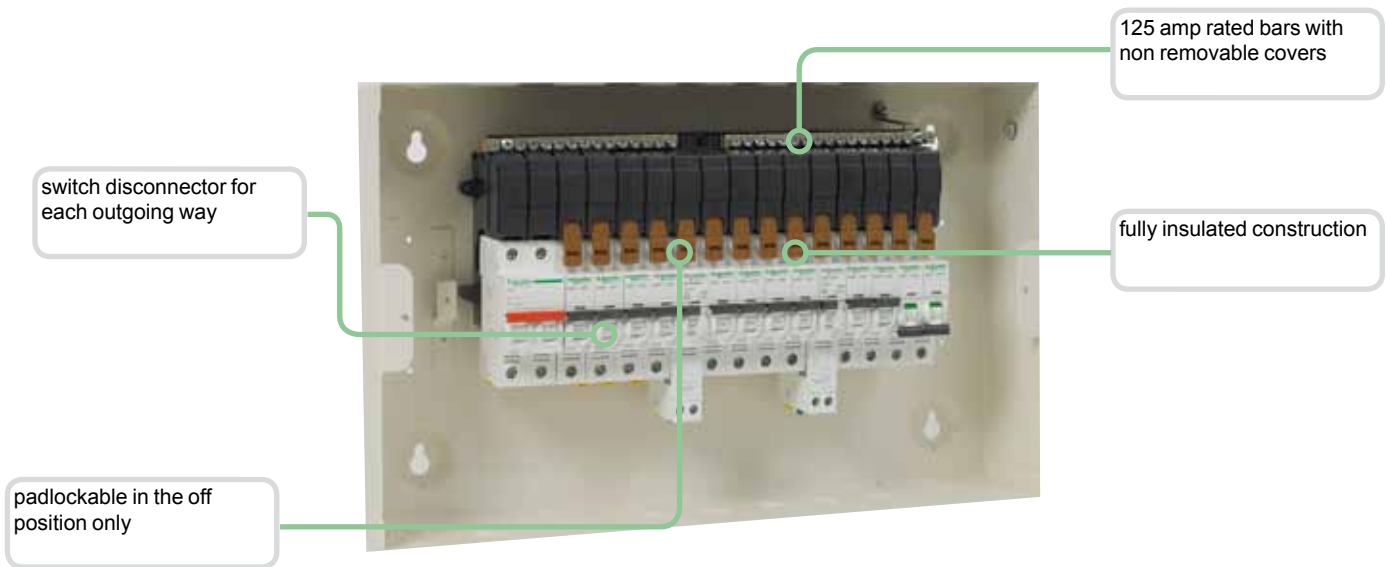

Technical data Standard, Meter ready, Split metered Acti9 Isobar

Main characteristics		110v	230/240v
According to BE EN 61439-3			
Withstand	conditional	25kA	25kA
	unconditional	25kA/50mS	25kA/50mS
		17kA/200mS	17kA/200mS
insulation voltage (Ui)			
Pollution degree			
Rated impulse withstand voltage (Uimp)			
Current rating (A)	direct connection	125	
	Switch disconnector	125	DIN mounted Power switch
	RCCB	100	
Degree of protection (IEC 60529)	sensitive (mA)	30, 100, 300, 300TD	
		External IP30	
		Internal IP20	
Endurance (O-C) Isobar switch disconnector		3000	
Overvoltage category		IV	
Operating temperature		-35 to +70°C	
Storage temperature		-40 to +80°C	
Connections			
Rating	tightening torque	Copper lugs	cables bare
125 amp		■	50mm
125 amp		■	50mm
100 amp		■	35mm
			device
			DIN switch disconnector
			Terminal block
			RCCB

Acti9 Isobar Dual supply distribution boards busbar rating 125amp		
incomers not included	Unprotected way	Protected ways
SEA9AN106DS	10	6
SEA9AN26DS	2	6
SEA9AN66DS	6	6

Acti9 Isobar Split metered distribution boards busbar rating 125amp direct connected meters		
incoming switch disconnector included	No of SP ways	No of DP ways
SEA9AN6S6 40A direct connected	6	6
SEA9AN10S10 63A direct connected	10	10

Acti9 Isobar A type distribution boards

Weight (kG) - Dimensions (mm)								
Standard	Multi service	Split load	Dual Incomer	Split metered	kG	Height	width	depth
2 way	■	■	■	■	1.8	300	200	117
6 way	■	■	■	■	2.5	300	273	117
10 way	■	■	2 - 6	■	3.0	300	345	117
14 way	6 - 16, 10 - 8	5 - 6	6 - 6	■	4.8	300	417	117
18 way	6 - 24, 10 - 16, 14 - 8	5 - 10, 9 - 6	10 - 6	6 - 6	5.7	300	489	117
27 way	14 - 32	■	■	10 - 10	8.9	530	417	117

Incomers			
Switch disconnecter		rating (A)	no of poles
SEA91252		125	2
Residual current circuit breaker 230/240vAC		rating (A)	no of poles
sensitivity (mA)			
SEA9R41263	30	63	2
SEA9R12263	100	63	2
SEA9R44263	300	63	2
SEA9211280	30	80	2
SEA9R12280	100	80	2
SEA9R14280	300	80	2
SEA9R15280	300 TD	80	2
SEA9R11291	30	100	2
SEA9R12291	100	100	2
SEA9R14291	300	100	2
SEA9R15291	300 TD	100	2
Terminal block		rating (A)	no of poles
SEA9TB1252		125	2

DIN rail only enclosures			
Reference	Description	number of rows	dimensions
SEA9DE16	8 SP way module enclosure	1	SEA9AN6
SEA9DE24	12 SP way module enclosure	1	SEA9AN10
SEA9DE32	16 SP way module enclosure	1	SEA9AN14
SEA9DE40	20 SP way module enclosure	1	SEA9AN18
SEA9DE64	32 SP way module enclosure	2	SEA9AN27

Accessories

Flush mounting kits		
Reference		no of ways
SEA9AN6FK	Flush mounting kit	6
SEA9AN10FK	Flush mounting kit	10
SEA9AN14FK	Flush mounting kit	14
SEA9AN18FK	Flush mounting kit	18
Distributed neutral kits		
Reference		no of ways
SEA9NA6	Distributed neut'l for 6 way SP+N	6
SEA9NA10	Distributed neut'l for 10 way SP+N	10
SEA9NA14	Distrib'd neut'l for 14 way SP+N	14
SEA9NA18	Distrib'd neut'l for 18 way SP+N	18
SEA9NA27	Distrib'd neut'l for 27 way SP+N	27
SEA9NKIT	Phase to neutral conversion kit (pack 4)	
Reference	Description	
SEA9BL	Door lock	
SEA9PD	Padlock kit for door	
SEA9BP	Blank pole	
SEA9BP25	Pack of 25 x 5 pole filler	
SEA9BP5	single 5 pole filler	
SEA9TB1001	100 amp terminal block 1 pole	
SEA9ANWL	SP&N LABELS	

Acti9 Isobar A type pan assemblies					
Reference		no of ways	height	width	depth
SEA9AN6PS	supplied without distributed neutral	6	202	200	87
SEA9AN10PS	supplied without distributed neutral	10	202	272	87
SEA9AN14PS	supplied without distributed neutral	14	202	344	87
SEA9AN18PS	supplied without distributed neutral	18	202	416	87

Acti9 Isobar B type distribution boards



BS EN 61439-3
IEC 61439-3

- Acti9 Isobar is a complete range of single and 3 phase
- distribution boards for commercial and industrial
- applications
- Standard distribution boards up to 24 ways
- Meter ready distribution boards up to 24 ways
- Split metered distribution boards up to 22 ways
- Any outgoing way can be converted to switch the Neutral

Alternating current (AC) 50Hz

	230/240v	400v	415v
withstand	25kA	25kA	25kA
conditional	25kA/50mS	25kA/50mS	25kA/50mS
unconditional	17kA/200mS	17kA/200mS	17kA/200mS

Direct current (DC)

	24v	48v	
unconditional	25kA/50mS	25kA/50mS	

Catalogue numbers

Acti9 Isobar Standard distribution boards busbar rating 250amp

	No of TP ways	No of SP ways	No of DP ways
SEA9BN4	4	12	6
SEA9BN6	6	18	9
SEA9BN8	8	24	12
SEA9BN12	12	36	18
SEA9BN16	16	48	24
SEA9BN18	18	54	26
SEA9BN24	24	72	36

Acti9 Isobar Meter ready distribution boards busbar rating 250amp

	No of TP ways	No of SP ways	No of DP ways
SEA9BN6M	6	18	9
SEA9BN8M	8	24	12
SEA9BN12M	12	36	18
SEA9BN16M	16	48	24
SEA9BN18M	18	54	26
SEA9BN24M	24	72	36

Acti 9 Isobar
the safest distribution board

Acti9 Isobar B type distribution boards

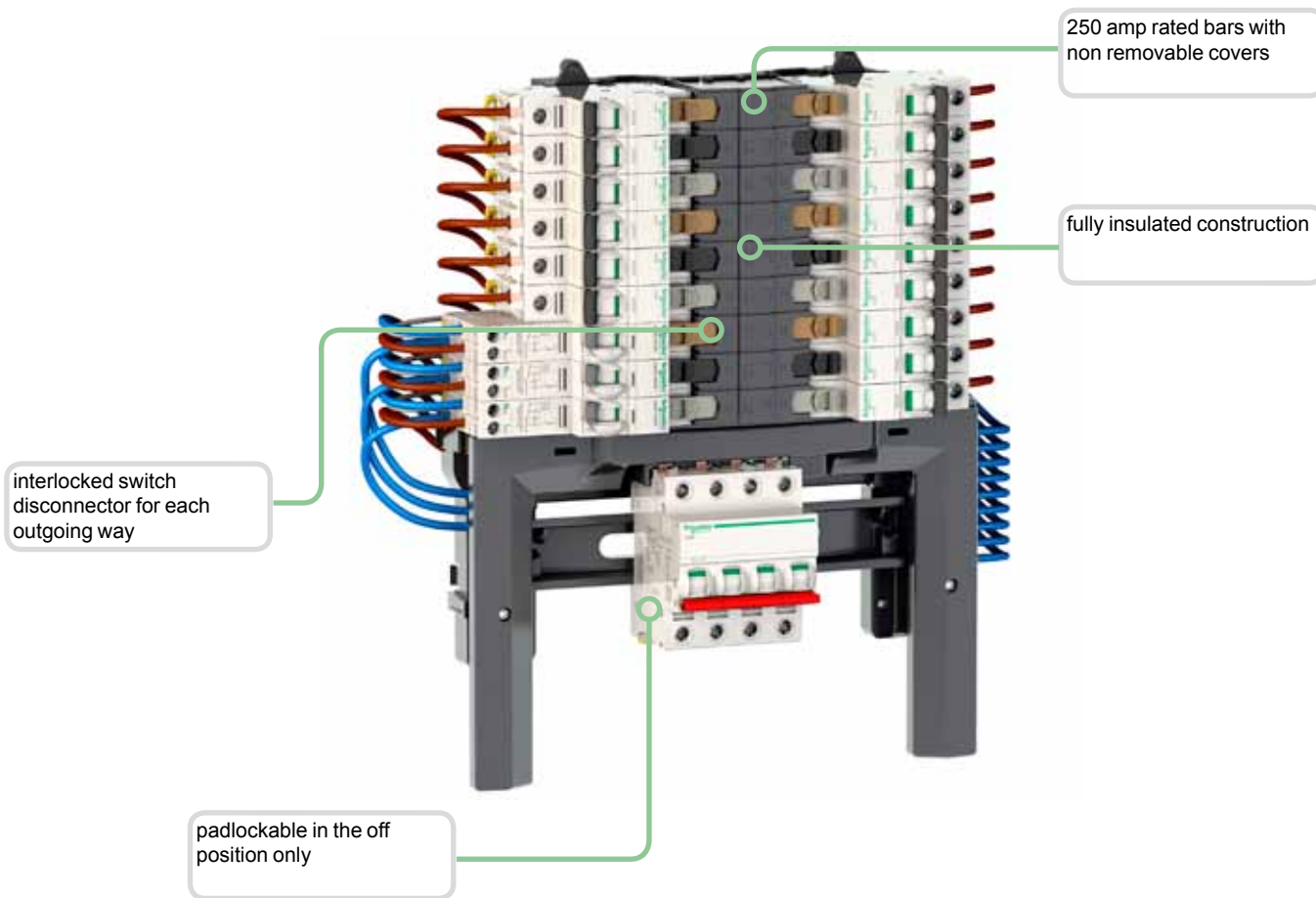

Acti9 Isobar Split metered* distribution boards busbar rating 125 amp

	lower pan assembly No of TP ways	No of SP ways	upper pan assembly No of TP ways	No of SP ways
SEA9BN1254S8	6	18	8	24
SEA9BN1258S8	8	24	8	24
SEA9BN12512S8	14	42	8	24
SEA9BN12514S6	16	48	6	18
SEA9BN12516S4	18	54	4	12

Acti9 Isobar Split metered* distribution boards busbar rating 250 amp

	lower pan assembly No of TP ways	No of SP ways	upper pan assembly No of TP ways	No of SP ways
SEA9BN2504S8	6	18	8	24
SEA9BN2508S8	8	24	8	24
SEA9BN25012S8	14	42	8	24
SEA9BN25014S6	16	48	6	18
SEA9BN25016S4	18	54	4	12

*MID 3 Phase kWh kit Modbus communications and pulsed output

Metering kits				
Acti9 Standard distribution boards			rating (A)	connection
SEA9BNKWH	MID 3 Phase kWh kit Modbus communications and pulsed output	height 270 (mm)	250	via CT
SEA9BNKWHP	MID 3 Phase kWh kit pulsed output	height 270 (mm)	250	via CT
SEA9BNMETE	Metering enclosure for standard Acti9 Isobar boards	height 270 (mm)	250	via CT
Acti9 Meter ready distribution boards			rating (A)	connection
SEA9BN3155	MID 3 Phase kWh kit Modbus communications and pulsed output	integral	63	direct
SEA9BN3110	MID 3 Phase kWh kit pulsed output	integral	63	direct
SEA9BN3255	MID 3 Phase kWh kit Modbus communications and pulsed output	height 135 (mm)	125	via CT
SEA9BN3210	MID 3 Phase kWh kit pulsed output	height 135 (mm)	125	via CT

Connections

Rating	Copper lugs	Bare cables	Device
125 amp	18	50mm	DIN switch disconnecter/Terminal block
		70mm with spreader connection	DIN switch disconnecter
160 -250 amp	95mm	185mm with cable clamps	Interpact Switch Disconnecter
	95mm	185mm with cable clamps	NSX Moulded case circuit breaker
	120 mm		Terminal block

Technical data Standard, Meter ready, Split metered Acti9 Isobar

Main characteristics		230/240v	400v	415v
Withstand	conditional	25kA	25kA	25kA
	unconditional	25kA/50mS	25kA/50mS	25kA/50mS
		17kA/200mS	17kA/200mS	17kA/200mS
insulation voltage (Ui)		500vAC	500vAC	500vAC
Pollution degree		3	3	3
Rated impulse withstand voltage (Uimp)		6kV	6kV	6kV
Current rating (A)	direct connection	125/250	6kV	6kV
	Switch disconnecter	125	DIN mounted Power switch	
		160-200-250	Interpact	
	MCCB	100-160-200-225-250		
Degree of protection (IEC 60529)		External IP30 or IP55		
Endurance (O-C) Isobar switch disconnecter		Internal IP20		
Overvoltage category		3000		
Operating temperature		IV		
Storage teperature		-35 to +70°C		
		-40 to +80°C		

Acti9 Isobar B type distribution boards



Main characteristics Acti9 Isobar IP55

According to BE EN 61439-3		230/240v	400v	415v
Withstand	conditional	25kA	25kA	25kA
	unconditional	25kA/50mS	25kA/50mS	25kA/50mS
		17kA/200mS	17kA/200mS	17kA/200mS
insulation voltage (Ui)		500vAC		
Pollution degree		3		
Rated impulse withstand voltage (Uimp)		6kV		
Current rating (A)		100A		
Degree of protection (IEC 60529)		External IP30 or IP55 Internal IP20		
Endurance (O-C) Isobar switch disconnecter		3000		
Overvoltage category		IV		
Operating temperature		-35 to +70°C		
Storage teperature		-40 to +80°C		

Catalogue numbers

Acti9 Isobar Standard IP55 distribution boards busbar rating 125amp steel door

	No of TP ways	No of SP ways	No of DP ways
SEA9BN6HDGR	6	18	9
SEA9BN8HDGR	8	24	12
SEA9BN12HDGR	12	36	18
SEA9BN16HDGR	16	48	24

Acti9 Isobar Standard IP55 distribution boards busbar rating 125amp transparent door

	No of TP ways	No of SP ways	No of DP ways
SEA9BN6HDGK	6	18	9
SEA9BN8HDGK	8	24	12
SEA9BN12HDGK	12	36	18
SEA9BN16HDGK	16	48	24

Weight (kG) - Dimensions (mm)

Standard	Meter ready	Split load	kG	Height	width	depth
4 way	■	■	9	484	470	139
6 way	6 way	■	10.5	484	470	138
8 way	6 way	■	11	538	470	138
12 way	12 way	■	13.5	700	470	139
16 way	16 way	■	16	808	470	139
18 way	18 way	■	16.2	862	470	139
24 way	24 way	■	22	1024		139
■	■	all versions	28	1294	470	139
250 amp incoming section			4	400	470	130
IP55			kG	Height	width	depth
6 way		■	32.4	650	600	330
8 way		■	32.9	650	600	330
12 way		■	40.1	800	600	330
16 way		■	41.4	800	600	330

Incommers							
Switch disconnector		rating (A)	no of poles	Standard	Meter ready	Split metered	IP55
SEA91253N		125	3P+N	Int	Int	Int	Int
SEA91254		125	4	Int	Int	Int	Int
SEA9NI1603		160	3P+N	Ext	Ext	Ext	■
SEA9NI1604		160	4	Ext	Ext	Ext	■
SEA9NI2003		200	3P+N	Ext	Ext	Ext	■
SEA9NI2004		200	4	Ext	Ext	Ext	■
SEA9NI2254		225	4	Ext	Ext	Ext	■
SEA9NI2503		250	3P+N	Ext	Ext	Ext	■
SEA9NI2504		250	4	Ext	Ext	Ext	n ■
Moulded Case Circuit Breaker		rating (A)	no of poles	Standard	Meter ready	Split metered	IP55
SEA9NCB1004		70-100	4	Ext	Ext	Ext	■
SEA9NCB1604		112-160	4	Ext	Ext	Ext	■
SEA9NCB2004		140-200	4	Ext	Ext	Ext	■
SEA9NCB2504		175-250	4	Ext	Ext	Ext	■
Residual current circuit breaker sensitivity (mA)		rating (A)	no of poles	Standard	Meter ready	Split metered	IP55
A9R41463	30	63	4	Int	Int	Int	Int
A9R12463	100	63	4	Int	Int	Int	Int
A9R44463	300	63	4	Int	Int	Int	Int
A9R15463	300/time delayed	63	4	Int	Int	Int	Int
A9R11480	30	80	4	Int	Int	Int	Int
A9R14491	300	100	4	Int	Int	Int	Int
A9R15491	300/time delayed	100	4	Int	Int	Int	Int
SEA9NI160RCCB	adjustable	160	■	Ext	Ext	Ext	■
Terminals for direct connection		rating (A)	no of poles	Standard	Meter ready	Split metered	IP55
SEA9TB1254		125	4	Int	Int	Int	Int
SEA9NTB2504		250	4	Ext	Ext	Ext	■
Dual source incomer		rating (A)	no of poles	Standard	Meter ready	Split metered	IP55
SEA9NDSI	*270mm enclosure	125	4	Ext	Ext	Ext	■
Contactor incomer		rating (A)	no of poles	Standard	Meter ready	Split metered	IP55
SEA9BN100CCI	*270mm enclosure	100	4	Ext	Ext	Ext	■
Dual metered extension enclosure		rating (A)	no of poles	Standard	Meter ready	Split metered	IP55
SEA9BNDM160SD	Interpact SD	160	4	Ext	■	■	■
SEA9BNDM200SD	Interpact SD	200	4	Ext	■	■	■
SEA9BNDM250SD	Interpact SD	250	4	Ext	■	■	■
SEA9BNDM160M	NSX MCCB	160	4	Ext	■	■	■
SEA9BNDM200M	NSX MCCB	200	4	Ext	■	■	■
SEA9BNDM250M	NSX MCCB	250	4	Ext	■	■	■
*MID 3 Phase kWh kit Modbus communications and pulsed output							
Single phasing kits		rating (A)	no of poles	Standard	Meter ready	Split metered	IP55
SEA9125SPEV		125	4	Int	Int	Int	Int
SEA9250SPEV		250	4	Int	Int	Int	Int

Int= Internal to the distribution board
Ext = in 400mm high extension enclosures
■ = not applicable

Acti9 Isobar B type distribution boards

Top or Bottom Extension enclosures height 270 (mm)		not applicable		
Switch disconnecter	Description			
SEA9BNEXN	plain front cover for additional wiring space			
SEA9BNEX034N	mounting of DIN devices, overall door and cutout for 17 x 18mm poles			
SEA9BNEXA15N	single phase add on distribution board 15 way			
Side Extension enclosures				
Reference	Description	No of rows	total 18mm SP ways	dimensions
SEA9N4SXS	Slotted front cover + overall door	2	34	SEA9BN4
SEA9N8SXS	Slotted front cover + overall door	2	34	SEA9BN8
SEA9N12SXS	Slotted front cover + overall door	3	51	SEA9NB12
SEA9N16SXS	Slotted front cover + overall door	4	68	SEA9NB16
SEA9N24SXS	Slotted front cover + overall door	5	85	SEA9NB24
SEA9N4SXP	Plain front cover+ overall door	2	34	SEA9BN4
SEA9N8SXP	Plain front cover+ overall door	2	34	SEA9BN8
SEA9N12SXP	Plain front cover+ overall door	3	51	SEA9NB12
SEA9N16SXP	Plain front cover+ overall door	4	68	SEA9NB16
SEA9N24SXP	Plain front cover+ overall door	5	85	SEA9NB24
Accessories				
Reference	Description	Reference	Description	
SEA9BL	Door lock	SEA9NB4	Distributed neut'I for 4 way TP+N	
SEA9PD	Padlock kit for door	SEA9NB6	Distributed neut'I for 6 way TP+N	
SEA9NEK1	Extra earth terminal bar 14 hole	SEA9NB8	Distributed neut'I for 8 way TP+N	
SEA9NEK2	Extra earth terminal bar 20 hole	SEA9NB12	Distrib'd neut'I for 12 way TP+N	
SEA9NEK3	Extra earth terminal 26 hole	SEA9NB16	Distrib'd neut'I for 16 way TP+N	
		SEA9NB18	Distrib'd neut'I for 18 way TP+N	
SEA9BN63SPL	split load lit 63 amp	SEA9NB24	Distrib'd neut'I for 24 way TP+N	
SEA9BNSJKN	Side joining kit	SEA9NKIT	Phase to neutral conversion kit (pack 4)	
SEA9BNTJKA	Top/bottom joining kit for enc/ext/enc			
SEA9BNTJKB	Top bottom kit replacing gland plate			
SEA9BNTJKN	Joining kit B board top/bottom			
SEA9BP	Blank pole			
SEA9BP25	Pack of 25 x 5 pole filler			
SEA9BP5	single 5 pole filler			
SEA9TB1001	100 amp terminal block 1 pole			
SEA9BNBCE7	clean earth B boards 7 hole			
SEA9BNBCE13	clean earth B boards 13 hole			
SEA9BNBCE25	Clean earth B boards 25 hole			
SEA9BNWL	TP&N LABELS			

Acti9 Isobar B type distribution boards

Pan assemblies - 3 phase without distributed neutral, supplied without mounting plate	
Reference	Description
SEA9BN4PS	Pan Assembly 4 way TP&N
SEA9BN6PS	Pan Assembly 6 way TP&N
SEA9BN8PS	Pan Assembly 8 way TP&N
SEA9BN12PS	Pan Assembly 12 way TP&N
SEA9BN16PS	Pan Assembly 16 way TP&N
SEA9BN18PS	Pan Assembly 18 way TP&N
SEA9BN24PS	Pan Assembly 24 way TP&N

Pan assemblies - replacement for Acti9 Isobar and Isobar 4c distribution boards	
Reference	Description
SEA9BN4P	B board replacement pan assembly
SEA9BN6P	B board replacement pan assembly
SEA9BN8P	B board replacement pan assembly
SEA9BN12P	B board replacement pan assembly
SEA9BN16P	B board replacement pan assembly
SEA9BN18P	B board replacement pan assembly
SEA9BN24P	b board replacement pan assembly

Pan assemblies - for switchboard mounting supplied with earths and neutral, phase coloured Isobar switch disconnectors	
Reference	Description
SEA9BN4E	pan assembly 4 way TP+ earth and neutral
SEA9BN6E	pan assembly 6 way TP+ earth and neutral
SEA9BN8E	pan assembly 8 way TP+ earth and neutral
SEA9BN12E	pan assembly 12 way TP+ earth and neutral
SEA9BN16E	pan assembly 16 way TP+ earth and neutral
SEA9BN18E	pan assembly 18 way TP+ earth and neutral
SEA9BN24E	pan assembly 24 way TP+ earth and neutral

Pan assemblies - for switchboard mounting supplied with earths and neutral, black Isobar switch disconnectors	
Reference	Description
SEA9BN4PEV	pan assembly 4 way TP+ earth and neutral
SEA9BN6PEV	pan assembly 6 way TP+ earth and neutral
SEA9BN8PEV	pan assembly 8 way TP+ earth and neutral
SEA9BN12PEV	pan assembly 12 way TP+ earth and neutral
SEA9BN16PEV	pan assembly 16 way TP+ earth and neutral
SEA9BN18PEV	pan assembly 18 way TP+ earth and neutral
SEA9BN24PEV	pan assembly 24 way TP+ earth and neutral

Pan assemblies - 3 phase without distributed neutral, supplied fitted on a mounting plate	
Reference	Description
SEA9BN4TN	4 TP&N way panel fixing pan assm
SEA9BN6TN	6 TP&N way panel fixing pan assm
SEA9BN8TN	8 TP&N way panel fixing pan assm
SEA9BN12TN	12 TP&N way panel fixing pan assm
SEA9BN16TN	16 TP&N way panel fixing pan assm
SEA9BN18TN	18 TP&N way panel fixing pan assm
SEA9BN24TN	24 TP&N way panel fixing pan assm

Acti9 Isobar B type distribution boards

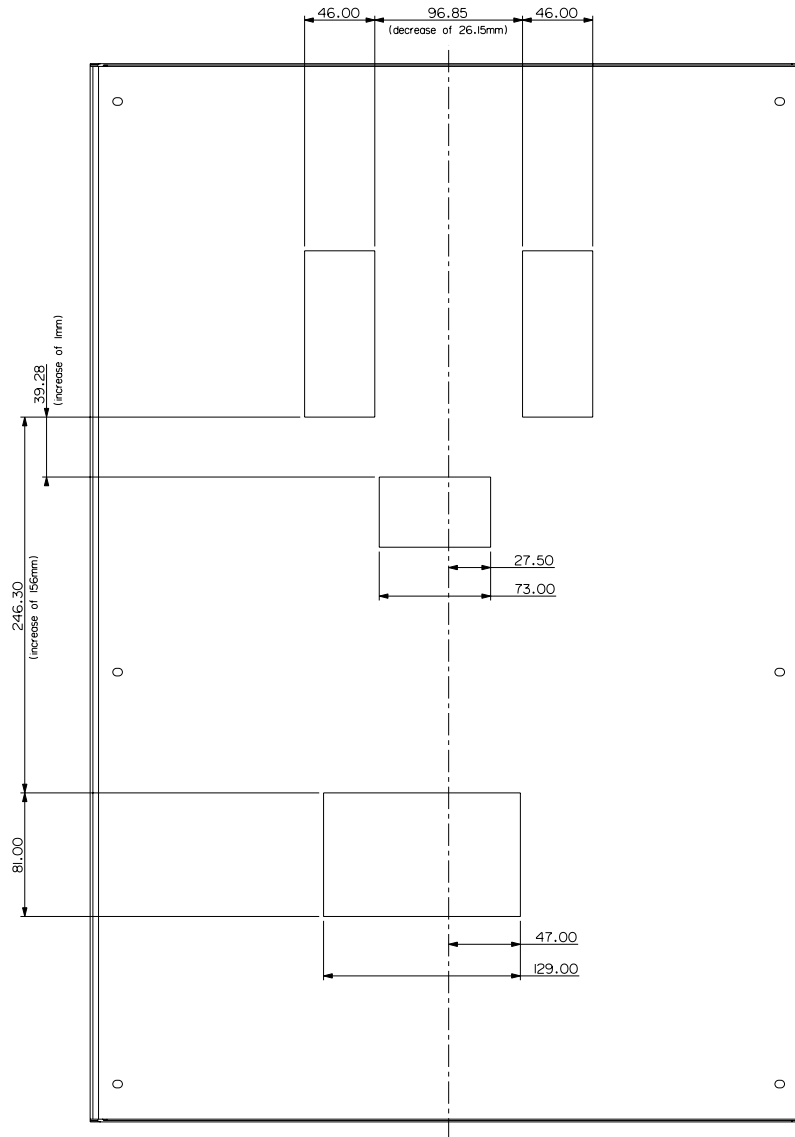

Pan assemblies - accessories	
Reference	Description
SEA9BINCKIT	250 amp incoming terminal block

iC60H circuit breakers (curve B, C, D)

BS/EN 60947-2
BS/EN 60898-1

- iC60H circuit breakers are multi-standard circuit breakers which combine the following functions:
 - circuit protection against short-circuit currents,
 - circuit protection against overload currents,
 - suitable for industrial isolation according to IEC/EN 60947-2, standard.
 - fault tripping indication by a red mechanical indicator in circuit breaker front face.



Alternating current (AC) 50/60 Hz

Breaking capacity (Icu) according to IEC/EN 60947-2						Service breaking capacity (Ics)
Ph/Ph (2P, 3P, 4P)	Voltage (Ue)					
Ph/N (1P)	12 to 133 V	220 to 240 V	380 to 415 V	440 V	-	100 % of Icu
Rating (In)	12 to 60 V	100 to 133 V	220 to 240 V	-	-	
1 to 4 A	70 kA	70 kA	70 kA	50 kA	50 kA	
6 to 40 A	42 kA	30 kA	15 kA	10 kA	10 kA	50 % of Icu
50/63 A	42 kA	-	15 kA	10 kA	10 kA	50 % of Icu



Breaking capacity (Icn) according to IEC/EN 60898-1	
	Voltage (Ue)
Ph/Ph	400 V
Ph/N	230 V
Rating (In)	1 to 63 A
	10000 A

Direct current (DC)

Breaking capacity (Icu) according to IEC/EN 60947-2						Service breaking capacity (Ics)
Between +/-	Voltage (Ue)					
	12 to 48 V	72 V	100 to 133 V	220 to 250 V	-	100 % of Icu
Number of poles	1P		2P (in series)	3P (in series)	4P (in series)	
Rating (In)	1 to 63 A	20 kA	10 kA	10 kA	10 kA	

Catalogue numbers

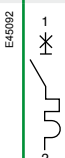
iC60H circuit breaker

Type	1P			2P		
	Calibre (In)			Calibre (In)		
Type						
	Courbe B C D			Courbe B C D		
1 A	A9F53101	A9F54101	A9F55101	A9F53201	A9F54201	A9F55201
2 A	A9F53102	A9F54102	A9F55102	A9F53202	A9F54202	A9F55202
3 A	A9F53103	-	-	-	-	-
4 A	A9F53104	A9F54104	A9F55104	A9F53204	A9F54204	A9F55204
6 A	A9F53106	A9F54106	A9F55106	A9F53206	A9F54206	A9F55206
10 A	A9F53110	A9F54110	A9F55110	A9F53210	A9F54210	A9F55210
16 A	A9F53116	A9F54116	A9F55116	A9F53216	A9F54216	A9F55216
20 A	A9F53120	A9F54120	A9F55120	A9F53220	A9F54220	A9F55220
25 A	A9F53125	A9F54125	A9F55125	A9F53225	A9F54225	A9F55225
32 A	A9F53132	A9F54132	A9F55132	A9F53232	A9F54232	A9F55232
40 A	A9F53140	A9F54140	A9F55140	A9F53240	A9F54240	A9F55240
50 A	A9F53150	A9F54150	A9F55150	A9F53250	A9F54250	A9F55250
63 A	A9F53163	A9F54163	A9F55163	A9F53263	A9F54263	A9F55263
Width in 9-mm modules	2			4		

(1) VDE approved only.

iC60H circuit breakers (curve B, C, D) (cont.)

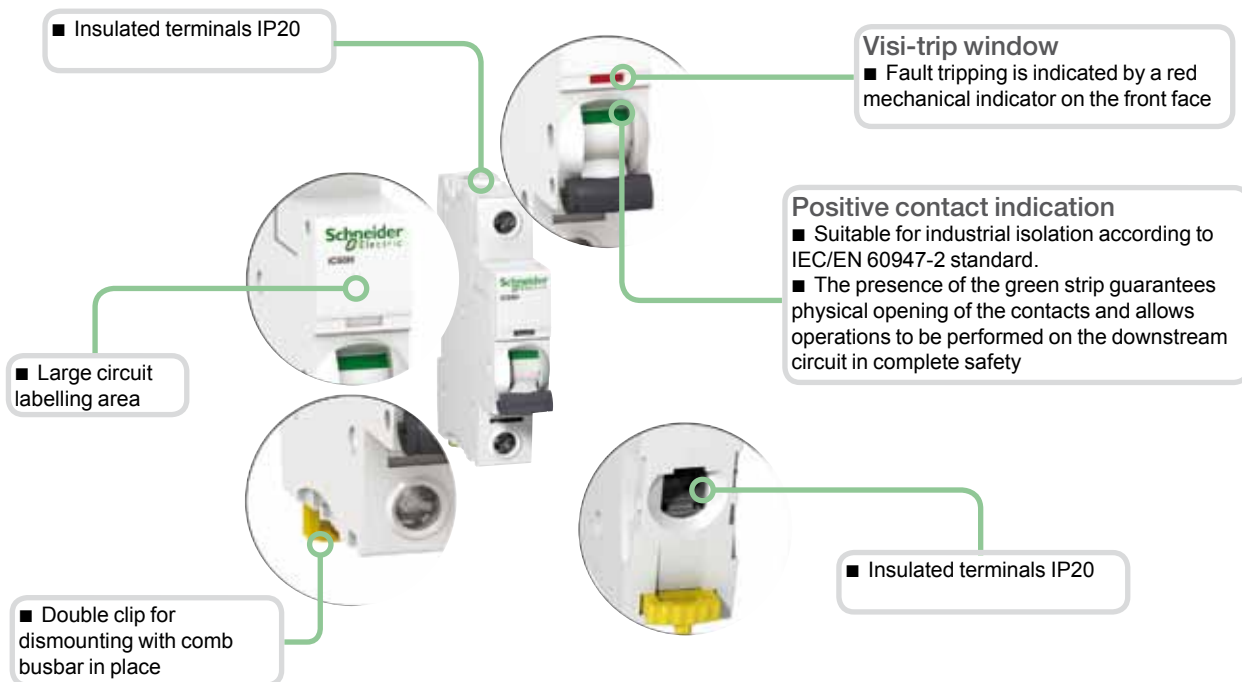

- Increased product service life thanks to:
 - overvoltage resistance by high level of industrial performances conception (pollution degree, rated impulse withstand voltage and insulation voltage),
 - high performance limitation (see limitation curves),
 - fast closing independent of the speed of actuation of the toggle.
- Remote indication, open/closed/tripped, by optional auxiliary contacts.
- Top or bottom electrical feeding.

E-46095	3P			E-46097	4P		
	B	C	D		B	C	D
	A9F53301	A9F54301	A9F55301	A9F53401	A9F54401	A9F55401	
	A9F53302	A9F54302	A9F55302	A9F53402	A9F54402	A9F55402	
	-	-	-	-	-	-	
	A9F53304	A9F54304	A9F55304	A9F53404	A9F54404	A9F55404	
	A9F53306	A9F54306	A9F55306	A9F53406	A9F54406	A9F55406	
	A9F53310	A9F54310	A9F55310	A9F53410	A9F54410	A9F55410	
	A9F53316	A9F54316	A9F55316	A9F53416	A9F54416	A9F55416	
	A9F53320	A9F54320	A9F55320	A9F53420	A9F54420	A9F55420	
	A9F53325	A9F54325	A9F55325	A9F53425	A9F54425	A9F55425	
	A9F53332	A9F54332	A9F55332	A9F53432	A9F54432	A9F55432	
	A9F53340	A9F54340	A9F55340	A9F53440	A9F54440	A9F55440	
	A9F53350	A9F54350	A9F55350	A9F53450	A9F54450	A9F55450	
	A9F53363	A9F54363	A9F55363	A9F53463	A9F54463	A9F55463	
6				8			

iC60H circuit breakers (curve B, C, D) (cont.)

Connection

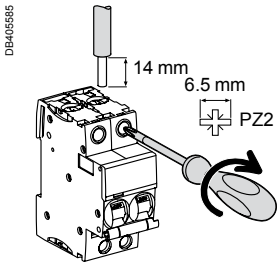

Rating	Tightening torque	Without accessory		With accessories			
		Copper cables	50 mm ² Al terminal	Screw-on connection for ring terminal	Multi-cables terminal		
		Rigid	Flexible or ferrule		Rigid cables	Flexible cables	
1 to 25 A	2 N.m	DB122945	DB122946	DB122945	DB118789	DB118787	
32 to 63 A	3.5 N.m	1 to 25 mm ²	1 to 16 mm ²	-	Ø 5 mm	-	
		1 to 35 mm ²	1 to 25 mm ²	50 mm ²		3 x 16 mm ²	3 x 10 mm ²

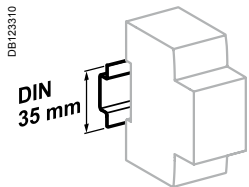

Clip on DIN rail 35 mm.

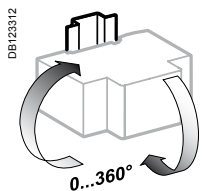

Indifferent position of installation.

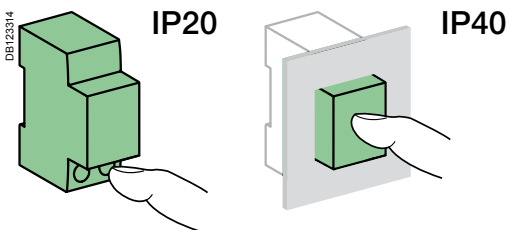

Technical data

Main characteristics		
According to IEC/EN 60947-2		
Insulation voltage (U _i)		500 V AC
Pollution degree		3
Rated impulse withstand voltage (U _{imp})		6 kV
Thermal tripping	Reference temperature	50 °C
Magnetic tripping	B curve	4 I _n ± 20 %
	C curve	8 I _n ± 20 %
	D curve	12 I _n ± 20 %
Utilization category		A
According to IEC/EN 60898-1		
Limitation class		3
Rated making and breaking capacity of an individual pole (I _{cn1})		I _{cn1} = I _{cn}
Additional characteristics		
Breaking capacity under 1 pole with IT 380-415 V isolated neutral system (case of double fault)	40 A	4 kA
	50/63 A	3 kA
Degree of protection (IEC 60529)	Device only	IP20
	Device in modular enclosure	IP40 Insulation classe II
Endurance (O-C)	Electrical	10,000 cycles
	Mechanical	20,000 cycles
Overvoltage category (IEC 60364)		IV
Operating temperature		-35°C to +70°C
Storage temperature		-40°C to +85°C
Tropicalization (IEC 60068-1)		Treatment 2 (relative humidity 95 % to 55°C)

iC60H circuit breakers (curve B, C, D) (cont.)

Weight (g)

Circuit-breaker	
Type	iC60H
1P	125
2P	250
3P	375
4P	500

Dimensions (mm)

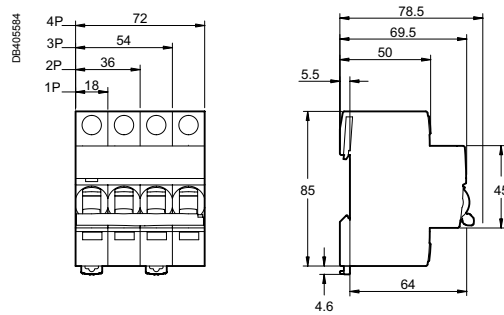



IEC 61009-1,
IEC 61009-2-2,
BS EN 61009-1
AS/NZS 61009.1

- The single-phase iC60H RCBO's self-contained residual current device carries out complete protection of final circuits:
 - protection against short-circuits and cable overloads
 - protection of persons against electric shock by direct contact (10, 30 mA sensitivities),
 - protection of persons against electric shock by indirect contact (100 mA sensitivity),
 - protection of equipment against fires set by leakage currents (100 mA sensitivity).
- The neutral is not interrupted when the device is tripped. Hence iC60H RCBO can be used on most circuits, except for the ones operating under TT or IT earthing systems.

Alternating current (AC) 50/60 Hz

Breaking capacity (I_{cn}) according to IEC 61009-1

Ph/N	Voltage (U_e)	
	110 V	240 V
Rating (I_n) 6 to 45 A	10000 A	10000 A

Accessory

Padlocking device

- Used to lock the toggle in the "open" or "closed" position by 4 mm diameter padlock (not supplied).

Catalogue numbers

iC60H RCBO 10000

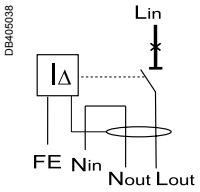
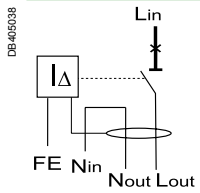
1P+N				A 			Width in 9-mm modules		
B curve	Voltage rating (V)	Sensitivity ($I_{\Delta n}$)	10 mA	30 mA	100 mA				
	240	Rating (I_n)	6 A	-	A9D31806	-	2		
			10 A	-	A9D31810	-			
			16 A	-	A9D31816	-			
			20 A	-	A9D31820	-			
			25 A	-	A9D31825	-			
			32 A	-	A9D31832	-			
			40 A	-	A9D31840	-			
			45 A	-	A9D31845	-			
	110	Rating (I_n)	10 A	-	A9D19810	-	2		
			16 A	-	A9D19816	-			
			20 A	-	A9D19820	-			
			25 A	-	A9D19825	-			
			32 A	-	A9D19832	-			
	240	Rating (I_n)	6 A	A9D10806	A9D11806	A9D12806			
			10 A	A9D10810	A9D11810	A9D12810			
			16 A	A9D10816	A9D11816	A9D12816			
			20 A	A9D10820	A9D11820	A9D12820			
			25 A	A9D10825	A9D11825	A9D12825			
			32 A	A9D10832	A9D11832	A9D12832			
			40 A	A9D10840	A9D11840	A9D12840			
			45 A	A9D10845	A9D11845	A9D12845			
			Operating frequency				50...60 Hz		

Accessory

Type	
Padlocking device (bag of 10 pieces)	A9A27049

Technical data

Main characteristics		iC60H RCBO
Insulation voltage (Ui)		
Rated impulse withstand voltage (Uimp)		
Rated residual operating current (IΔn)		10, 30, 100 mA
Thermal tripping	Reference temperature	
Temperature derating		
Limitation class		
Surge current withstand (8/20 μs) without tripping		
Rated nominal breaking capacity (Icn)		10,000 A
Phase/earth rated residual breaking and making capacity (IΔm)		7,500 A
Additional characteristics		
Degree of protection	Device only	
	Device in modular enclosure	
Endurance (O-C)	Electrical	
	Mechanical	
Operating temperature		
Storage temperature		
Tropicalization		

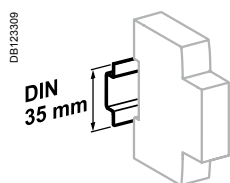

Clip on DIN rail 35 mm.

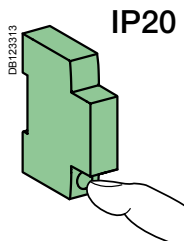

IP20

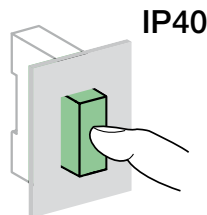

IP40

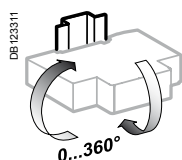

Indifferent position of installation.

Weight (g)

iC60 RCBO	
iC60N RCBO	205
iC60H RCBO	205
iC60H2 RCBO	332

Dimensions (mm)

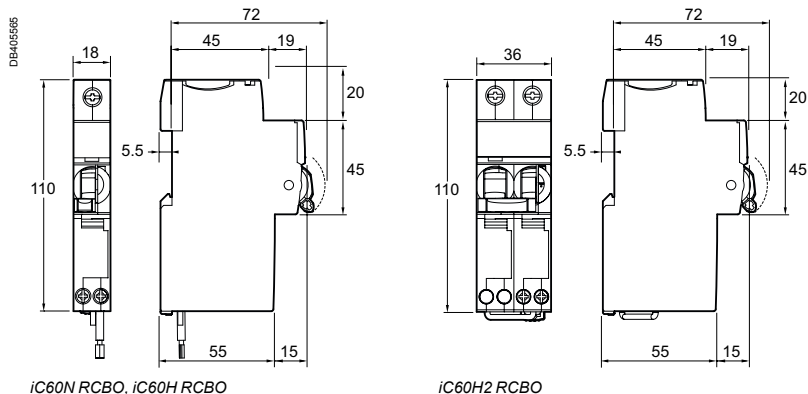

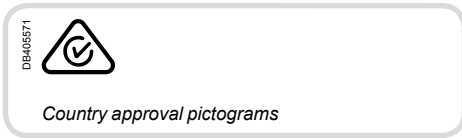

IEC/EN 61009-1

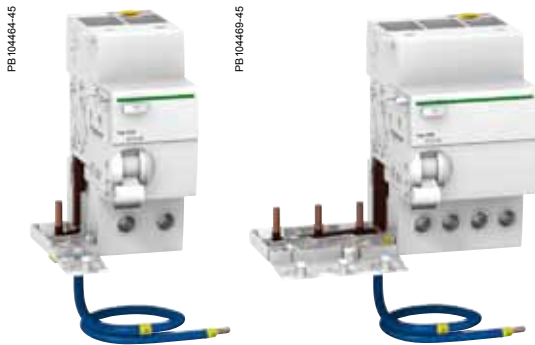

- Combined with iC60 circuit breaker, the Vigi iC60 provide:
 - protection of persons against electric shock by direct contact (≤ 30 mA),
 - protection of persons against electric shock by indirect contact (≥ 100 mA),
 - protection of installations against the risk of fire (300 mA).

Catalogue numbers

Vigi iC60 add-on residual current devices							
Type	A					Width in 9 mm modules	
Product	Vigi iC60						
Auxiliaries	Without auxiliaries						
DB122462 	Sensitivity Rating	10 mA	30 mA	100 mA	300 mA		
		25 A	A9V00625				3
		63 A	-	A9V02663 A9V01663*	A9V03663	A9V06663	4
DB122464 	Sensitivity Rating	10mA	30 mA	100 mA	300 mA		
		63 A	-	A9V02763	-	A9V06763	7
Voltage rating (Ue)	230 - 240 V, 400 - 415 V Except * 110 V						
Operating frequency	50/60 Hz						

Vigi iC60 add-on residual current devices (AC, A, *SI* types) (cont.)

PB104466-40

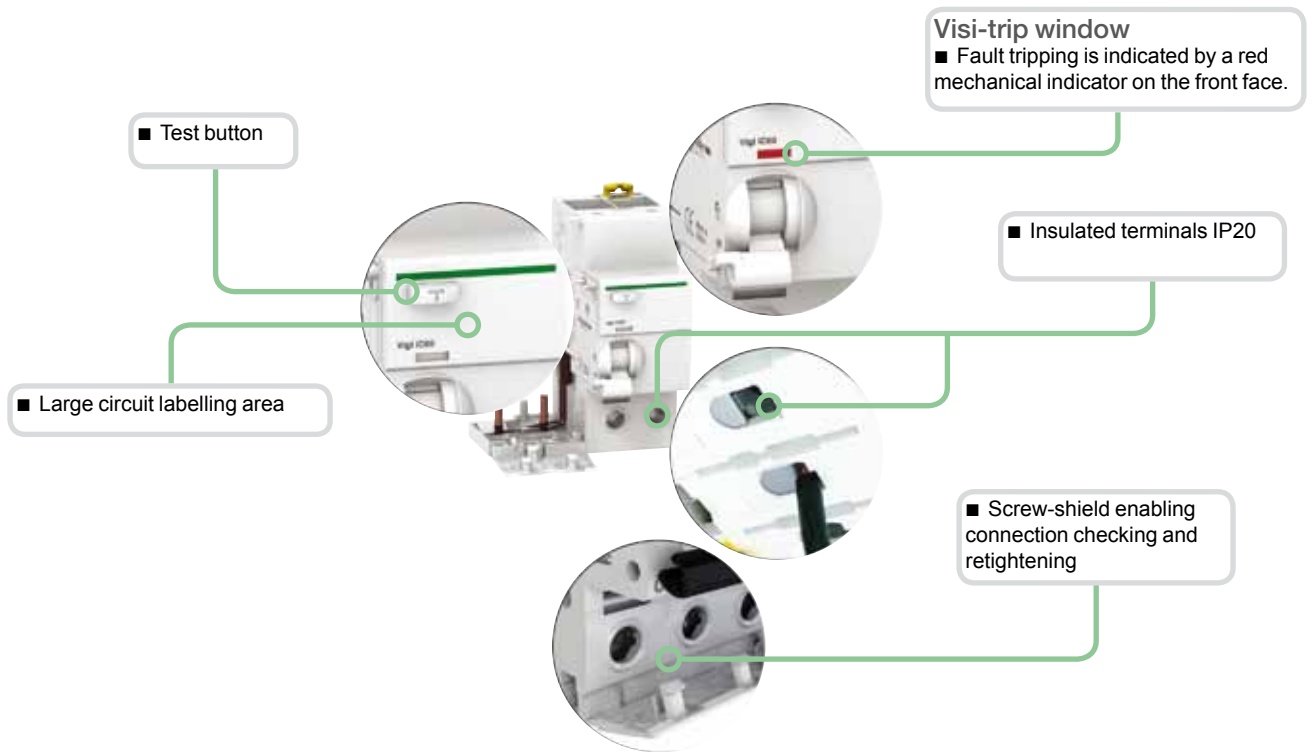



SI type

The *SI* type provides increased immunity from electrical interference and polluted or corrosive environments.

Vigi iC60 add-on residual current devices (A type)

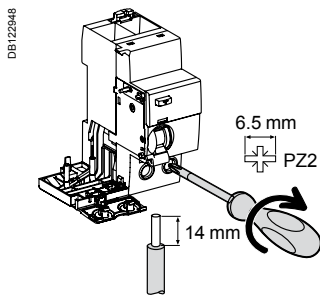
Connection



Type	Rating	Tightening torque	Copper cables	
			Rigid	Flexible or ferrule
Vigi iC60	25 A	2 N.m	 1 to 25 mm ²	 1 to 16 mm ²
	40 to 63 A	3.5 N.m		

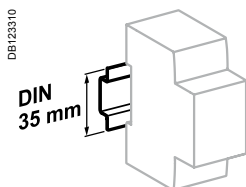

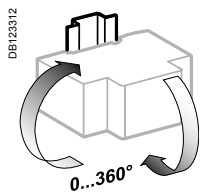

Clip on DIN rail 35 mm.



Indifferent position of installation.

Technical data

Main characteristics		
Insulation voltage (U _i)		500 V
Pollution degree		3
Rated impulse withstand voltage (U _{imp})		6 kV
According to IEC/EN 61009-1		
Surge current withstand (8/20 μs) without tripping	A type (no selective )	250 Å
	A type (selective )	3 kÅ
Additional characteristics		
Degree of protection	Device only	IP20
	Device in modular enclosure	IP40
Operating temperature	AC type	-5°C to +60°C
	A and S/ types	-25°C to +60°C
Storage temperature		-40°C to +85°C

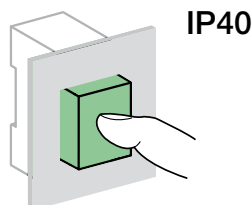
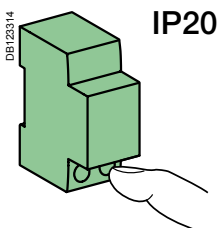

■ The electrical auxiliaries are combined with iC60 circuit breakers, iID residual current circuit breakers, remote tripping switch disconnectors iSW-NA, RCA remote controls and ARA automatic reclosers; they enable tripping or remote indication of their position (open/closed/tripped) upon a fault.

■ They are fastened by clips (without tools) to the left side of the breaker.

■ The iOF/SD+OF auxiliary is a 2-in-1 product: via a mechanical selector switch, it provides two contacts, OF+SD or OF+OF.

■ The iOF+SD24 auxiliary can report open/closed (OF) status information and intentional or fault tripping of the associated device (SD) to the Acti 9 Smartlink or a programmable logic controller via the TI24 interface (24 V DC).

Tripping auxiliaries:

IEC/EN 60947-1

- iMN: undervoltage release
- iMNs: delayed undervoltage release
- iMNx: undervoltage release, independent from supply voltage
- iMX: shunt release
- iMX+OF: shunt release with open/close contact.

EN 50550

- iMSU: overvoltage release

Indication auxiliaries:

IEC/EN 60947-5-1

- iOF: open/close contact
- iSD: fault indicating contact
- iOF/SD+OF: open/close contact and switchable OF or SD contact.

IEC/EN 60947-5-4

- iOF+SD24: open/close contact OF and default indicating contact SD with TI24 interface.

DB404939



Electrical auxiliaries for iC60, iID, RCA and ARA (cont.)

The mounting order for the various auxiliaries must be complied with.
 The tripping auxiliaries (iMN, iMX) should be mounted first, as close as possible to the circuit breaker or the residual current circuit breaker. Then, the indicating auxiliaries (iOF, iSD) should be mounted, complying with their position shown in the following table.

Indicating auxiliaries

PE104474-25



PE104475-25



DB123583













1 (iOF/SD+OF or iOF+SD24 or iSD)	1 iOF/SD+OF
1 iOF	1 (iSD or iOF or iOF/SD+OF)
None	1 iOF+SD24
None	None
1 iSD	1 iSD
None	1 (iSD or iOF or iOF/SD+OF or iOF+SD24)
1 iOF	1 (iSD or iOF or iOF/SD+OF)
None	1 (iSD or iOF or iOF/SD+OF or iOF+SD24)
1 iOF	1 (iSD or iOF or iOF/SD+OF)







Tripping devices must be mounted first. Comply with the position of the SD function.

***iSW-NA : the iSD auxiliary contact must be associated with an auxiliary (iMN, iMX, iMX+OF); it indicates that the remote tripping switch disconnecter has been tripped open.**

	Tripping auxiliaries	Remote control	Device	Vigi iC60
		ARA automatic recloser or RCA remote control	iC60 circuit breaker or iID residual current circuit breaker	Vigi iC60 add-on residual current device
PB104496-25	1 (iMN, iMNs, iMNx or iMX, iMX+OF or iMSU) max.	-	 iC60	 Vigi iC60
	2 (iMN, iMNs, iMNx or iMX, iMX+OF or iMSU) max.	-	-	-
	2 (iMN, iMNs, iMNx or iMX, iMX+OF or iMSU) max.	-	-	-
	3 iMSU max.	-	-	-
	1 (iMN, iMNs, iMNx or iMX, iMX+OF or iMSU) max.	-	 iID/iSW-NA	-
	1 (iMN, iMNs, iMNx or iMX, iMX+OF or iMSU) max.	 ARA	 iC60	 Vigi iC60
	None	 iID	-	-
	1 (iMX or iMN or iMSU) max.	 RCA	 iC60	 Vigi iC60
	None	-	-	-

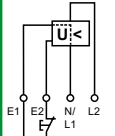

Electrical auxiliaries for iC60, iID, iDPN Vigi, iSW-NA, RCA and ARA (cont.)

		Tripping					
Auxiliaries		iMN		iMNs		iMNx	
Type		Undervoltage release					
	Instantaneous	Delayed		Independent of the supply voltage			
							
Function		<ul style="list-style-type: none"> Trips the device with which it is combined when its input voltage decreases (between 70 % and 35 % U_n). Prevents device closing again until its input voltage is restored 		<ul style="list-style-type: none"> Not tripping on transient voltage dip (up to 0.2 s) 		<ul style="list-style-type: none"> Tripping of the associated device by opening of the control circuit (e.g. push-button, dry contact) A drop in the supply voltage does not trip the associated device A locking push-button control allows the circuit protected (e.g. machine control) to be placed in safety configuration 	
Wiring diagrams							
Use		<ul style="list-style-type: none"> Emergency stoppage by normally closed push button Ensures the safety of power supply circuits for several machines by preventing "uncontrolled" restarting 		<ul style="list-style-type: none"> Emergency stoppage with fail-safe principle Insensitive to control circuit voltage variation to increase service continuity Important: Before any servicing operation switch off the mains power supply (voltage presence at terminals E1/E2) 			
Catalogue numbers		A9A26960	A9A26961	A9A26959	A9A26963	A9A26969	A9A26971
iC60, iID, iDPN Vigi, iSW-NA, RCA et ARA		■	■	■	■	■	■
iC60, iID double terminals		■	■	■	■	■	■
Technical specifications							
Rated voltage (Ue)	V AC	220...240	48	115	220...240	220...240	380...415
	V DC	—	48	—	—	—	—
Standardised operating and non-response to voltage times (U_a)*		—	—	—	—	—	—
Maximum operating time		—	—	—	—	—	—
Minimum non-response time		—	—	—	—	—	—
Operating frequency	Hz	50/60	—	400	50/60	50/60	—
Red mechanical indicator		On front face			On front face		On front face
Test function		—			—		—
Width in 9 mm modules		2			2		2
Operating current		—			—		—
Number of contacts		—			—		—
Operating temperature	°C	-35...+70			-35...+70		-35...+70
Storage temperature	°C	-40...+85			-40...+85		-40...+85



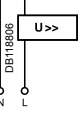
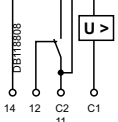

*(U_a)

Voltages measured between the phase and the neutral conductor, at which the IMSU device must control the associated protective device.

Electrical auxiliaries for iC60, iID, iDPN Vigi, iSW-NA, RCA and ARA (cont.)



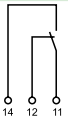
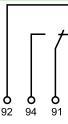
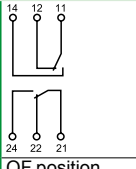
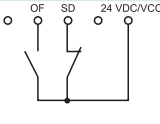

iMSU					iMX			iMX+OF		
Overvoltage release					Shunt release			With Open/Close auxiliary contact		
										
<ul style="list-style-type: none"> Switches off the power supply by opening the breaker with which it is combined, in the event that the phase/neutral voltage is exceeded (loss of neutral). For a four-phase network, use three iMSU tripping auxiliaries 					<ul style="list-style-type: none"> Trips the breaker when powered 			<ul style="list-style-type: none"> Includes an open/close contact (OF) to indicate the "open" or "closed" position of the breaker 		
										
<ul style="list-style-type: none"> Protection of equipment against overvoltages on the electrical network (neutral conductor break) Voltage monitoring between phase and neutral conductors 					<ul style="list-style-type: none"> Emergency stoppage by normally open push button 			<ul style="list-style-type: none"> Emergency stoppage by normally open push button Remote indication of the position of the associated breaker 		
A9A26500					A9A26476	A9A26477	A9A26478	A9A26946	A9A26947	A9A26948
■					■	■	■	■	■	■
■					■	■	■	■	■	■
230					100...415	48	12...24	100...415	48	12...24
-					110...130	48	12...24	110...130	48	12...24
255 V AC	275 V AC	300 V AC	350 V AC	400 V AC	-	-	-	-	-	-
No tripping	15 s	5 s	0.75 s	0.20 s	-	-	-	-	-	-
	3 s	1 s	0.25 s	0.07 s	-	-	-	-	-	-
50/60					50/60			50/60		
On front face					On front face			On front face		
-					-			-		
2					2			2		
-					-			≤ 24 V DC	10 mA mini, 6 A maxi	
-					-			48 V DC	2 A	
-					-			≤ 130 V DC	1 A	
-					-			≤ 240 V AC	6 A	
-					-			415 V AC	3 A	
-					-			1 NO/NC		
-35...+70					-35...+70			-35...+70		
-40...+85					-40...+85			-40...+85		

Electrical auxiliaries for iC60, iID, iDPN Vigi, iSW-NA, RCA and ARA (cont.)

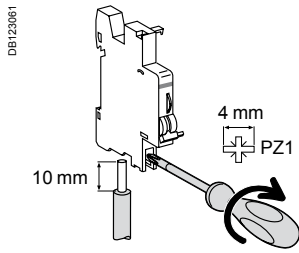
		Indication						
Auxiliaries		iOF	iSD	iOF/SD+OF	iOF+SD24			
Type		Open/close auxiliary contact	Fault indicating contact	Double open/close or fault indicating contact	Double open/close and fault indicating contact			
								
Function		<ul style="list-style-type: none"> Changeover contact indicates "open" or "closed" position of the breaker 	<ul style="list-style-type: none"> Changeover contact indicates position of the breaker; upon: <ul style="list-style-type: none"> electrical fault action on tripping auxiliary Same indication as VISI-TRIP 	<ul style="list-style-type: none"> The iOF/SD+OF auxiliary is a 2-in-1 product: via a mechanical selector switch, it provides two contacts, OF+SD or OF+OF 	<ul style="list-style-type: none"> 2 contacts (1 NO + 1 NC) can report the signalling information of the associated device to the Acti 9 Smartlink or a programmable logic controller: <ul style="list-style-type: none"> electrical fault actuation of the tripping auxiliary "Open" or "Closed" position of the associated device 			
Wiring diagrams								
Use		<ul style="list-style-type: none"> Remote indication of the position of the associated breaker 	<ul style="list-style-type: none"> Remote indication of tripping upon a fault of the associated breaker 	<ul style="list-style-type: none"> Remote indication of position and/or tripping upon a fault of the associated breaker 	<ul style="list-style-type: none"> Remote indication of position and tripping upon a fault of the associated breaker 			
Catalogue numbers		A9A26924	A9A26869	A9A26927	A9A26855	A9A26929	A9A26897	
iC60, iID, iDPN Vigi, iSW-NA, RCA et ARA		■	—	■	—	■	■	
iC60, iID double terminals		—	■	—	■	■	■	
Technical specifications								
Rated voltage (Ue)	V AC	240...415		240...415		240...415		-
	V DC	24...130		24...130		24...130		24
Operating frequency	Hz	50/60		50/60		50/60		-
Red mechanical indicator		—		On front face		On front face		On front face
Test function		On toggle		On toggle		On toggle		On toggle
Width in 9 mm modules		1		1		1		1
Operating current	24 V DC	10 mA mini, 6 A maxi		10 mA mini, 6 A maxi		10 mA mini, 6 A maxi		2 mA mini, 50 mA maxi
	48 V DC	2 A		2 A		2 A		-
	60 V DC	1.5 A		1.5 A		1.5 A		-
	130 V DC	1 A		1 A		1 A		-
	240 V AC	6 A		6 A		6 A		-
	415 V AC	3 A		3 A		3 A		-
Number of contacts		1 NO/NC		1 NO/NC		1 NO/NC + 1 NO/NC		1 NO/NC
Operating temperature	°C	-35...+70		-35...+70		-35...+70		-25...+70
Storage temperature	°C	-40...+85		-40...+85		-40...+85		-40...+85



Connection

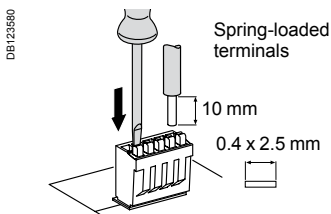

Type	Tightening torque	Copper cables		Multi-cables terminal	
		Rigid	Flexible	Rigid cables	Cables with ferrule
	DB122945				
Indication auxiliaries	1 N.m	1 to 4 mm ²	0.5 to 2.5 mm ²	2 x 2.5 mm ²	2 x 1.5 mm ²
Tripping auxiliaries	1 N.m	1 to 6 mm ²	0.5 to 4 mm ²	2 x 2.5 mm ²	2 x 2.5 mm ²

Ti24 connector connection



Type	Catalogue numbers	Copper cables	
		Rigid	Flexible
	DB122945		
Ti24 interface	A9XC2412	1 x 0,5 à 1,5 mm ²	1 x 0,5 à 1,5 mm ²

Ti24 prefabricated cables connection

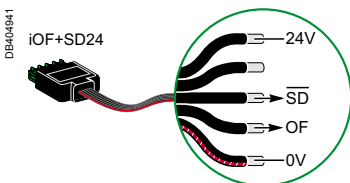

Type	Catalogue numbers	Length
Connection for Acti 9 Smartlink		
6 short prefabricated	A9XCAS06	100 mm
6 medium-sized prefabricated	A9XCAM06	160 mm
6 long prefabricated	A9XCAL06	870 mm
Connection for PLC type terminals		
6 long prefabricated on a single side	A9XCAU06	870 mm

		Mounting						
Accessories		Rotary handle			Plug-in base			
Function		<p>Front or side-mounted control</p> <ul style="list-style-type: none"> ■ Degree of protection: IP55 rotary handle ■ Installation: <ul style="list-style-type: none"> □ the control mechanism is mounted on the device □ the rotary handle is fixed to the front or side of the enclosure ■ Front-mounted (on door or faceplate) <ul style="list-style-type: none"> ■ Prevents the door from opening when the device is in the ON position (can be deactivated) ■ Can be padlocked when the device is in the "open" position (can be padlocked with the device in the "closed" position subject to adaptation) ■ Can be locked by padlock of (dia. 5 to 8 mm), not supplied with the device ■ Pushbutton: iID test available in the front face of the rotary handle 			<ul style="list-style-type: none"> ■ The Laser Square tool brings the accuracy to align the circuit breaker and the rotary handle 		<p>Allows a breaker to be removed or replaced quickly, without handling the connections</p> <ul style="list-style-type: none"> ■ Degree of protection: IP20 ■ Consists of: <ul style="list-style-type: none"> □ a base to be fastened on a rail (or panel) □ 2 "blades" to be fastened in the device's terminals ■ Connection: tunnel terminals for cable up to 35 mm² rigid, 25 mm² flexible, ■ Installation: <ul style="list-style-type: none"> □ in universal enclosure □ on horizontal rail ■ Height: 178 mm ■ Not compatible with Vigi iC60 and auxiliaries ■ Can be locked by padlock of (dia. 6 mm), not supplied with the device 	
Catalogue numbers	A9A27005	A9A27006	A9A27008	GVAPL01	A9A27003 (1 per pole)			
	Operating sub-assembly							
	+	+						
	Black handle	Red handle	No handle					
Set of	1	1	1	1	1			
Suitability								
iC60	■ 2P, 3P, 4P				■			
iSW	■ 2P, 3P, 4P				■			
iC60 + Vigi iC60	■ 2P, 3P, 4P				-			
iID	■				■ ≤ 63 A			
Reflex iC60 or RCA+iC60 or ARA+iC60	-				-			
ARA+iID	-				-			

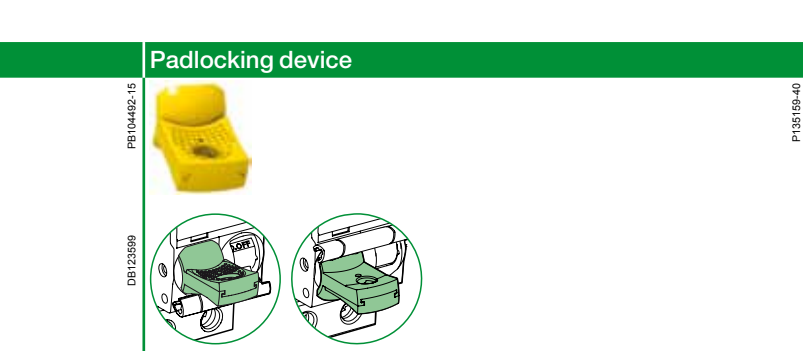











Used to padlock breaker in open or closed position

- Padlock diameter: 3 to 6 mm
- Sealable (max. diameter: 1.2 mm)
- Locking in ON position does not prevent tripping of the breaker in the event of faults
- Suitable for IEC/EN 60947-2 compliant disconnection

MCB	RCBO
A9A26970	A9A27049
10	10

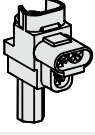
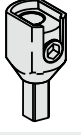
■
■
■
■
■
■

Security						
Accessories	Screw shield		Terminal shield		Inter-pole barrier	Spacer
						
Function	<p>Prevents any contact with the connecting screws</p> <ul style="list-style-type: none"> ■ Upgrades degree of protection to IP20D ■ Sealable, max. diameter 1.2 mm 		<p>Prevents any contact with the terminals</p> <ul style="list-style-type: none"> ■ Upgrades degree of protection to IP20D ■ Sealable, max. diameter 1.2 mm ■ Set of two, for upstream and downstream terminals ■ For 3 poles: A9A26975 + A9A26976 ■ For 4 poles: 2 X A9A26976 		<p>Enhances insulation between connections: cables, terminals, lugs, etc</p>	<ul style="list-style-type: none"> ■ Used to: <ul style="list-style-type: none"> <input type="checkbox"/> complete rows <input type="checkbox"/> separate devices. Width: 1 x 9 mm module ■ Allows cable routing from one row to another, (above and below), up to 6 mm²
Catalogue numbers	A9A26982	A9A26981	A9A26975	A9A26976	A9A27001	A9A27062
Set of	12 x 1 pole	20 x 4 poles (splittable)	2 x 1 pole	2 x 2 poles	10	5
Suitability						
iC60	-	■	■	■	■	■
iSW	-	-	■	■	■	■
Vigi iC60	■	-	-	-	-	-
iID	-	■	-	■	■	■
Reflex iC60 or RCA+iC60 or ARA+iC60	-	■	■	■	■	■
ARA+iID	-	■	-	■	■	■

		Connection		
Accessories	Multi-cable terminal		50 mm ² terminal Al	Screw-on connection for ring terminal
				
Function				
	For 3 copper cables: ■ Rigid up to 16 mm ² ■ Flexible up to 10 mm ²		For aluminium cables from 16 to 50 mm ²	For lug tipped cables, front or rear mounting
				 Ø 5 mm
Catalogue numbers	19091	19096	27060	27053
Set of	4	3	1	8
iC60 ≤ 25 A Reflex iC60 ≤ 25 A	–	–	–	■
iC60 >25 A Reflex iC60 40 A, iSW	■	■	■	■
Vigi iC60	–	–	–	–
iID	■	■	■	■
iDPN Vigi	–	–	–	■
iSW-NA	■	■	■	■
Tightening torque	2 N.m		10 N.m	2 N.m
Length stripping	11 mm		13 mm	–
Tools to use	Dia. 5 mm or PZ2		Hc 1/5" or 5 mm	Dia. 5mm

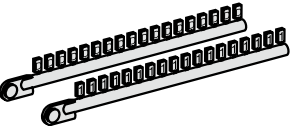
		Marking					
Accessories	Marker strip						
							
Used for connection identification							
Catalogue numbers	0: AB1-R0 1: AB1-R1 2: AB1-R2 3: AB1-R3 4: AB1-R4	5: AB1-R5 6: AB1-R6 7: AB1-R7 8: AB1-R8 9: AB1-R9	A: AB1-GA B: AB1-GB C: AB1-GC D: AB1-GD E: AB1-GE F: AB1-GF G: AB1-GG H: AB1-GH I: AB1-GI	J: AB1-GJ K: AB1-GK L: AB1-GL M: AB1-GM N: AB1-GN O: AB1-GO P: AB1-GP Q: AB1-GQ R: AB1-GR	S: AB1-GS T: AB1-GT U: AB1-GU V: AB1-GV W: AB1-GW X: AB1-GX Y: AB1-GY Z: AB1-GZ	+ : AB1-R12 - : AB1-R13 blank: AB1-RV	
Set of	250						
iC60, Reflex iC60, iSW	■ 4 markers max. per pole						
Vigi iC60	■ 4 markers max. per device						
iID	■ 4 markers max. per device						
iDPN Vigi	■ 4 markers max. per device						
iSW-NA	■ 4 markers max. per device						

iID residual current circuit breakers (AC type)

IEC/EN 61008-1

FB10472-40



FB10473-40



- The iID residual current circuit breakers provide:
 - protection of persons against electric shock by direct contact (≤ 30 mA),
 - protection of persons against electric shock by indirect contact (≥ 100 mA),
 - protection of installations against the risk of fire (300 mA or 500 mA).

Catalogue numbers

iID residual current circuit breakers										
Type	AC								Width in 9 mm module	
Product	iID									
Auxiliaries										
2P	Sensitivity	10 mA	30 mA	100 mA	300 mA	500 mA	300 mA	500 mA		
<p>DB122476</p>	Rating	16 A	A9R10216	-	-	-	-	-	4	
		25 A	A9R10225	A9R41225	-	A9R44225	A9R16225	-		
		40 A	-	A9R41240	A9R12240	A9R44240	A9R16240	-		
		63 A	-	A9R41263	A9R12263	A9R44263	A9R16263	A9R15263		
		80 A	-	A9R11280	A9R12280	A9R14280	-	A9R15280		
		100 A	-	A9R11291	A9R12291	A9R14291	-	A9R15291		
<p>DB122477</p>	Rating	25 A	-	A9R41425	-	A9R44425	A9R16425	-	8	
		40 A	-	A9R41440	A9R12440	A9R44440	A9R16440	A9R15440		A9R17440
		63 A	-	A9R41463	A9R12463	A9R44463	A9R16463	A9R15463		A9R17463
		80 A	-	A9R11480	A9R12480	A9R14480	A9R16480	A9R15480		A9R17480
		100 A	-	A9R11491	A9R12491	A9R14491	-	A9R15491		-
Voltage rating (Ue)	2P	230 - 240 V								
	4P	400 - 415 V								
Operating frequency	50/60 Hz									

iID residual current circuit breakers (A type)

IEC/EN 61008-1

PB10472-40







PB10473-40

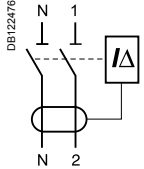

- The iID residual current circuit breakers provide:
 - protection of persons against electric shock by direct contact (≤ 30 mA),
 - protection of persons against electric shock by indirect contact (≥ 100 mA),
 - protection of installations against the risk of fire (300 mA or 500 mA).

Catalogue numbers

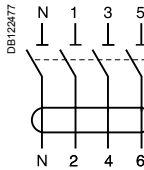
iID residual current circuit breakers									
Type	A 							Width in 9 mm module	
Product	iID								
Auxiliaries									
2P	Sensitivity	10 mA	30 mA	100 mA	300 mA	500 mA	300 mA 		
 <p>DB122476</p>	Rating	16 A	A9R20216	-	-	-	-	4	
		25 A	A9R20225	A9R21225	-	A9R24225	-		-
		40 A	-	A9R21240	-	A9R24240	-		A9R25240
		63 A	-	A9R21263	-	A9R24263	-		A9R25263
		100 A	-	A9R21291	-	A9R24291	-		A9R25291
4P	Sensitivity	10 mA	30 mA	100 mA	300 mA	500 mA	300 mA 		
 <p>DB122877</p>	Rating	25 A	-	A9R21425	-	A9R24425	-	8	
		40 A	-	A9R21440	A9R22440	A9R24440	A9R26440		A9R25440
		63 A	-	A9R21463	A9R22463	A9R24463	A9R26463		A9R25463
		80 A	-	A9R21480	-	A9R24480	-		A9R25480
		100 A	-	A9R21491	-	A9R24491	A9R26491		A9R25491
Voltage rating (Ue)	2P	230 - 240 V							
	4P	400 - 415 V							
Operating frequency	50/60 Hz								

IEC/EN 61008-1

PB104472-40







PB104473-40



- The iID residual current circuit breakers provide:
 - protection of persons against electric shock by direct contact (≤ 30 mA),
 - protection of persons against electric shock by indirect contact (≥ 300 mA),
 - protection of installations against the risk of fire (300 mA or 500 mA).

The **SI** type provides increased immunity from electrical interference and polluted or corrosive environments.

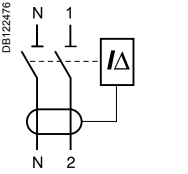
Catalogue numbers

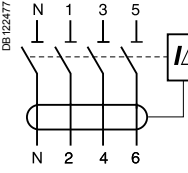
iID residual current circuit breakers							
Type	SI 						Width in 9 mm module
Product	iID						
Auxiliaries							
2P	Sensitivity	10 mA	30 mA	300 mA	300 mA 	500 mA 	
	Rating	16 A	-	-	-	-	4
	25 A	A9R30225	A9R61225	-	-	-	
	40 A	-	A9R61240	-	-	A9R35240	
	63 A	-	A9R61263	-	-	A9R35263	
	100 A	-	-	-	-	A9R35291	
4P	Sensitivity	10 mA	30 mA	300 mA	300 mA 	500 mA 	
	Rating	25 A	-	A9R61425	-	-	8
	40 A	-	A9R61440	-	-	A9R35440	A9R37440
	63 A	-	A9R61463	A9R34463	A9R35463	A9R37463	
	80 A	-	A9R31480	-	-	A9R35480	A9R37480
	100 A	-	A9R31491	A9R34491	A9R35491	-	
Voltage rating (Ue)	2P	230 - 240 V					
	4P	400 - 415 V					
Operating frequency	50/60 Hz						

iID residual current circuit breakers (AC, A, *SI* types) (cont.)



PB104548-40

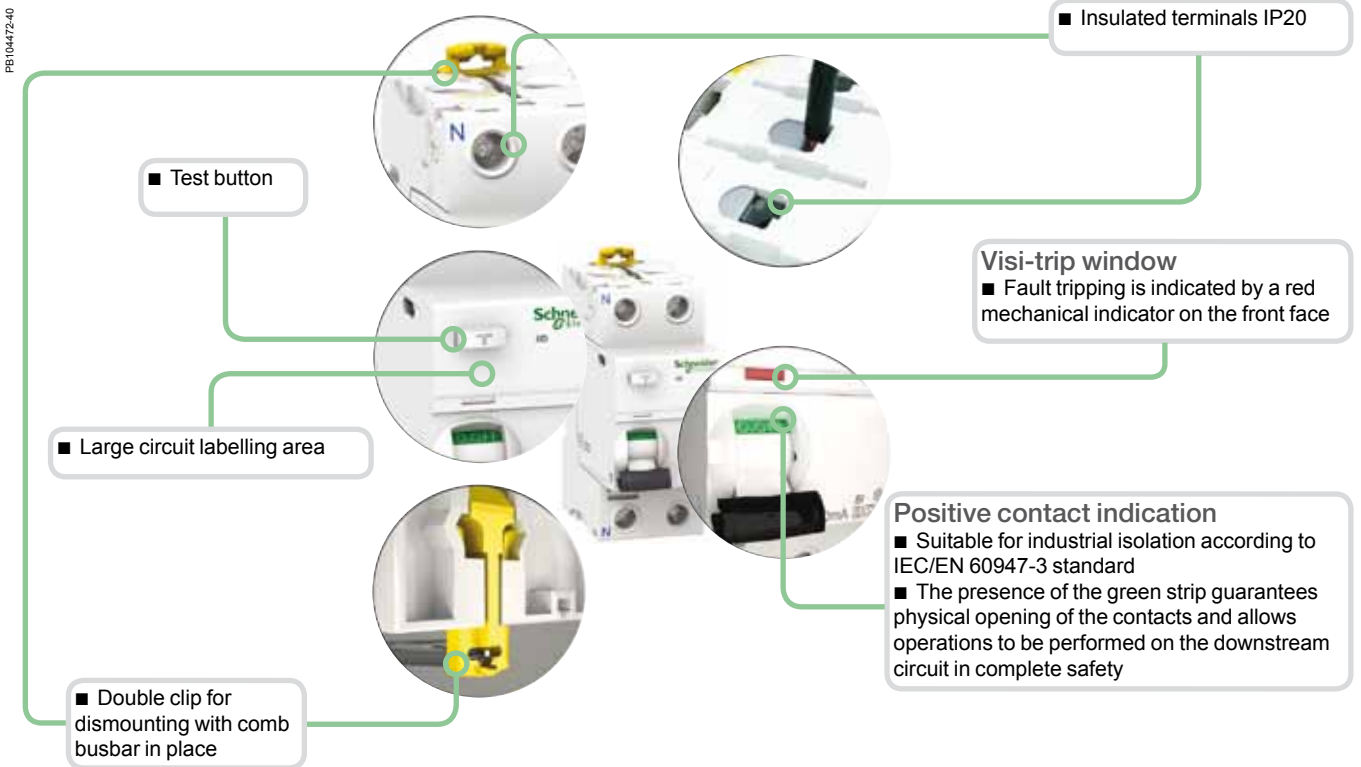

PB104472-40

SI type

The *SI* type provides increased immunity from electrical interference and polluted or corrosive environments.

iID residual current circuit breakers (AC, A, S/I types)

Connection

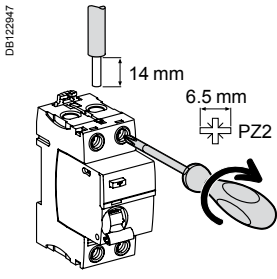

Type	Tightening torque	Without accessory		With accessories*			
		Copper cables		50 mm ² Al terminal	Screw-on connection for ring terminal	Multi-cables terminal	
		Rigid	Flexible or ferrule			Rigid cables	Flexible cables
iID	3.5 N.m	1 to 35 mm ²	1 to 25 mm ²	50 mm ²	∅ 5 mm	3 x 16 mm ²	3 x 10 mm ²

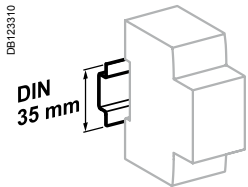

Clip on DIN rail 35 mm.

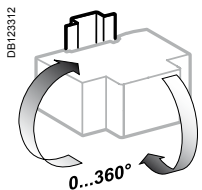

Indifferent position of installation.

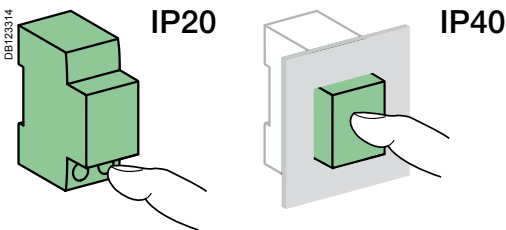

Technical data

Main characteristics			
Insulation voltage (U _i)		500 V	
Pollution degree		3	
Rated impulse withstand voltage (U _{imp})		6 kV	
According to IEC/EN 61008-1			
Making and breaking capacity (I _m /I _∞ m)		1500 A	
Surge current withstand (8/20 μs) without tripping	AC and A types (no selective Ⓜ)	250 Å	
	AC, A types (selective Ⓜ)	3 kÅ	
	S/I type	3 kÅ	
Conditional rated short circuit current (I _{nc} /I _{∞c})	With iC60N/H/L	Equal to breaking capacity of iC60	
	With fuse	10,000 A	
Additional characteristics			
Degree of protection	Device only	IP20	
	Device in modular enclosure	IP40	
Endurance (O-C)	Electrical (AC1)	16 to 63 A	15,000 cycles
		80 to 100 A	10,000 cycles
	Mechanical	20,000 cycles	
Operating temperature	AC type	-5°C to +60°C	
	A and S/I types	-25°C to +60°C	
Storage temperature		-40°C to +85°C	

Technical advice

Principal of catalogue number	Pg 62
Dissipated power, Impedance and Voltage drop	Pg 63
Tripping curves	Pg 66
Influence of ambient temperature	Pg 72
Short-circuit current limiting	Pg 79
Direct current applications	Pg 97
400 Hz network	Pg 111

Principle of catalogue numbers

iID, iC60, Vigi iC60, Reflex iC60, switches

A9 R 15 2 63

Range	Family	Code	Internal code	Poles	Code	Rating (A)	Code
Acti 9 (A9)	iID	R		0	0	0	00
	Vigi iC60	V		1P	1	0.5	70
	iC60	F		2P	2	0.75	71
	Auxiliaries and accessories	A		3P	3	1	01
	Switches	S		4P	4	1.6	72
	Reflex iC60	C		1N	5	2	02
				1P+N	6	2.5	73
				3P+N	7	3	03
						4	04
						6	06
						6.3	76
						8	08
						10	10
						12.5	82
						13	13
						16	16
						20	20
						25	25
						32	32
						40	40
						50	50
						63	63
						80	80
						100	91
						125	92

Comb busbar and comb busbar accessories

A9 X P H 4 12

Range	Family	Code	Type	Type of installation	Number of poles	Dimensioning			
Acti 9 (A9)	Comb busbar	X	Comb busbar		1P	1	Comb busbar		
			Fork teeth	F	Horizontal			H	Number of 18 mm modules (approximately)
			Pin teeth	P			2P	2	Accessories
			Auxiliarisable	A			3P		
			Accessories				4P	4	
			End-piece	E	Double terminals	D	4P balanced, with neutral	5	
			Tooth cover	T	Single terminal	M	3P balanced for single-poles	6	
			Connector	C					

Dissipated power, Impedance and Voltage drop

Acti 9 products

The following table indicates the average dissipated power per pole in W for a current equal to the rating of the device and at the operating voltage.

Rating (A)	0.5	1	1.6	2	2.5	3	4	6	6.3	10	12.5	13	16	20	25	32	40	50	63	80	100	125		
Circuit breakers																								
iC60	2.3	2.3		1.9		2.2	2.4	1.3		2		2	2.1	2.2	2.7	2.8	3.6	4	5.6					
iC60L-MA			0.7		0.2		0.6		0.9	1.1	1.5		1.6		0.8		2							
		2.3		1.9		2.2	2.4	2.7		1.8			2.5	3	3.1	3.5	3.6	4	5.6					
RCCB																								
iID 2P													0.8		0.9		2.6		2.6	3	5			
4P															0.7		1.9		1.5	2.6	4.3			
															2.7		3.6		5.6					
Add-on residual current devices																								
Vigi iC60 10 mA															3									
30 mA															1.4		1.1		2.3					
100 mA															1.1				2.3					
300 mA															1.3		0.9		2.3					
500 mA															1.1		0.9		2.3					
1000 mA																			2.3					
Contactors																								
iCT/iCT+ Power circuit													0.6	0.9	1.4		1.5		3.4		4			
Control circuit	See module CA904007																							
Impulse relays																								
iTL/iTL+ Power circuit													0.6			1.5								
Control circuit	See module CA904008																							
Push-buttons																								
iPB														0.6										
Selector switches																								
iSSW														0.8										
iCMA/iCMB/iCMC/ iCMD/iCMV									0.4															
Switch-disconnectors																								
iSW														0.8		1.3	1.1		1.8		3.4	4.2		
iSW-NA 2P																	0.7		1.8		3	5		
4P																	0.6		1.5		2.5	4.1		
Indication auxiliaries																								
iOF, iSD, iOF/SD+OF	See module CA908028																							
Déclencheurs auxiliaires																								
iMN, iMNs, iMNx, iMX+OF, iMX, iMSU	See module CA908029																							
Indicator lights																								
iIL	0.3																							

Note: When the enclosure's thermal balance, consider the 4P devices load is only on 3 phases

Impedance calculation:

$$Z = P / I^2$$

Z: impedance in Ohms

P: dissipated power in Watts (table values)

I: rating in Amperes

Voltage drop calculation:

$$U = P / I$$

U: voltage drop in Volts

P: dissipated power in Watts (table values)

I: rating in Amperes

Dissipated power, Impedance and Voltage drop (cont.)

Multi 9 products

The following table indicates the average dissipated power per pole in W for a current equal to the rating of the device and at the operating voltage.

Rating (A)	0.5	1	1.6	2	2.5	3	4	6	6.3	10	12.5	13	16	20	25	32	40	50	63	80	100	125
Circuit breakers																						
DPN		2.5		1.9		2.1	2.6	2.7		2.7		3.3	3.2	4.7	4.7	4.6	5.8					
C60/C60H-DC	2.2	2.3		2.6		2.2	2.4	2.7		1.8		2.5	2.5	3	3.1	3.5	4.3	4.8	6.1			
C120										1.3			2.1	2.3	2.5	3.2	3.1	3.2	3	3.2	2	4.1
NG125										1.7			2.4	2.7	2.7	3.8	3.8	4.2	3.8	4.8	4.3	7.9
C60L-MA			2.4		2.5		2.4		3	2	2.5		2.6		3		4.6					
NG125L-MA							3		2	2	3.1		2.5		3.2		4		5.5	6		
RCCB																						
ID Type A/AC															1.4		3.6		4.4	7.2	18	28
ID Type B															1.2		2.9		7.2	12	18	28
Contactors																						
CT/CT+ Power circuit													0.9				1.4					
Control circuit	See module 92020																					
Impulse relays																						
TL/TL+ Power circuit													0.9			1.4						
Control circuit	See module 92011																					
Push-buttons																						
PB														0.6								
Selector switches																						
CM														0.8								
CMA/CMB/CMC/CMD/CMV									0.4													
Switch-disconnectors																						
I													0.8		1.3	1.1		1.8		3.4	4.2	
I-NA																3.2		3.2				
NG125NA																		5.5	6	7	9	
Indication auxiliaries																						
OF, SD, OF/SD+OF	See module 92605																					
Tripping auxiliaries																						
MN, MNs, MNx, MX+OF, MX, MSU	See module 92605																					
Indicator lights																						
V	0.3																					

Note: When the enclosure's thermal balance, consider the 4P devices load is only on 3 phases

Impedance calculation:

$$Z = P / I^2$$

Z: impedance in Ohms

P: dissipated power in Watts (table values)

I: rating in Amperes

Voltage drop calculation:

$$U = P / I$$

U: voltage drop in Volts

P: dissipated power in Watts (table values)

I: rating in Amperes

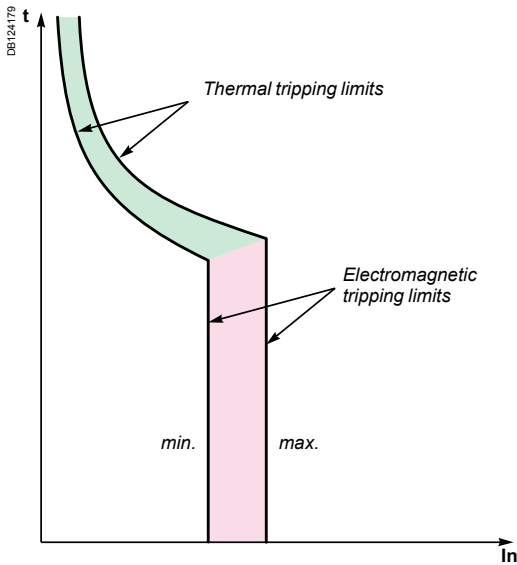

The following curves show the total fault current breaking time, depending on its amperage. For example: based on the curve on page 3, an iC60 circuit breaker of curve C, 20 A rating, will interrupt a current of 100 A (5 times the rated current I_n) in:

- 0.45 seconds at least
- 6 seconds at most.

The circuit breakers' tripping curves consist of two parts:

- tripping of overload protection (thermal tripping device): the higher the current, the shorter the tripping time
- tripping of short-circuit protection (magnetic tripping device): if the current exceeds the threshold of this protection device, the breaking time is less than 10 milliseconds. For short-circuit currents exceeding 20 times the rated current, the time-current curves do not give a sufficiently precise representation. The breaking of high short-circuit currents is characterized by the current limiting curves, in peak current and in energy. The total breaking time can be estimated at 5 times the value of the ratio $(I^2t)/(I)^2$.

Verification of the discrimination between two circuit breakers

By superimposing the curve of a circuit breaker on that of the circuit breaker installed upstream, one can check whether this combination will be discriminating in cases of overload (discrimination for all current values, up to the magnetic threshold of the upstream circuit breaker). This verification is useful when one of the two circuit breakers has adjustable thresholds; for fixed-threshold devices, this information is provided directly by the discrimination tables.

To check discrimination on short circuit, the energy characteristics of the two devices must be compared.

Tripping curves

According to IEC/EN 60898-1 standards

Alternative current 50/60 Hz

iC60

According to IEC/EN 60898-1 (reference temperature 30°C)

Curves B, C, D rating up to 4 A

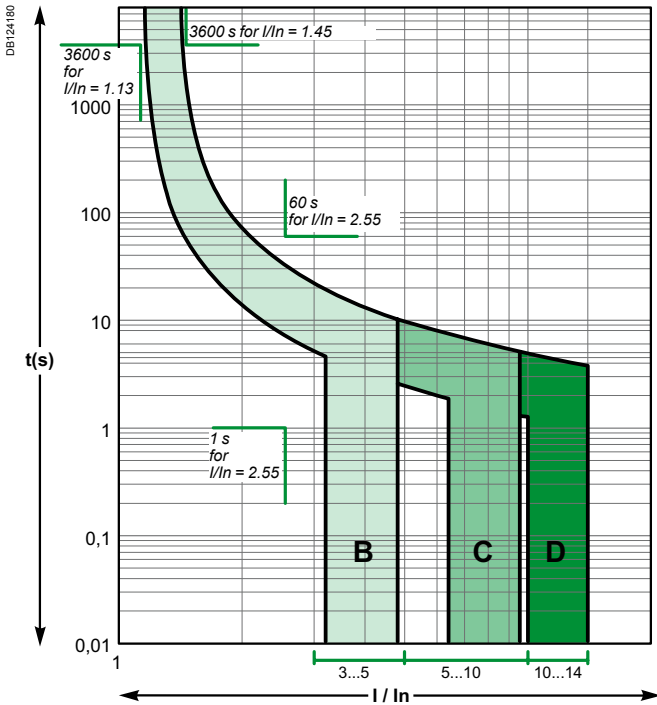

Curves B, C, D rating 6 A to 63 A

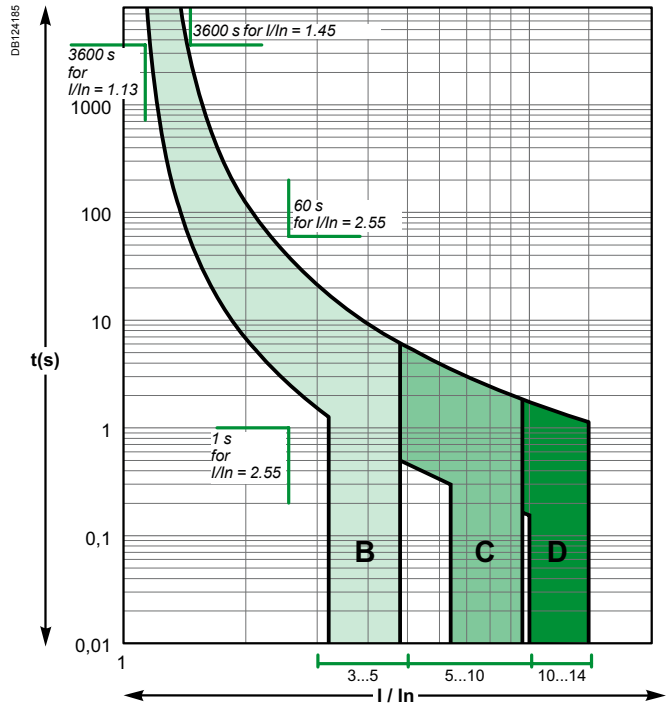

C120N/H

According to IEC/EN 60898-1 (reference temperature 30°C)

Curves B, C, D

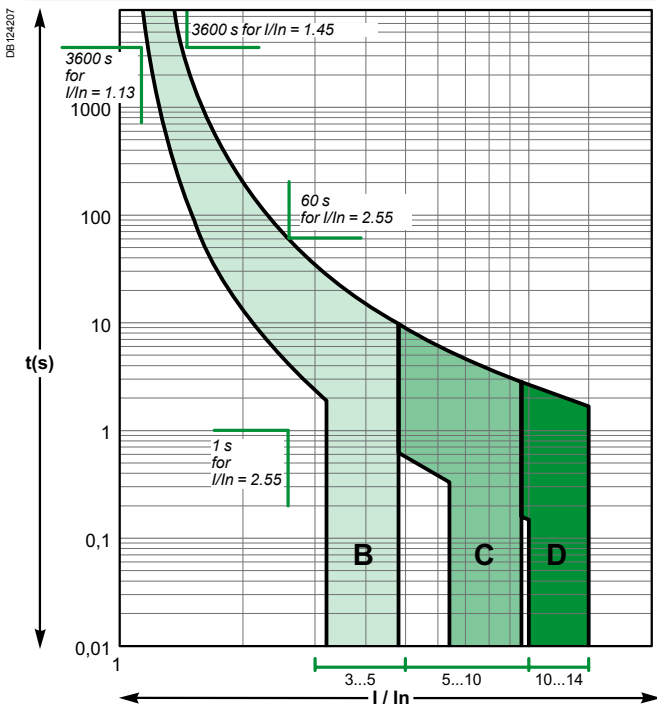

DPN, DPN N (circuit-breaker and residual current device)

According to IEC/EN 60898-1 (reference temperature 30°C)

Curves B, C, D

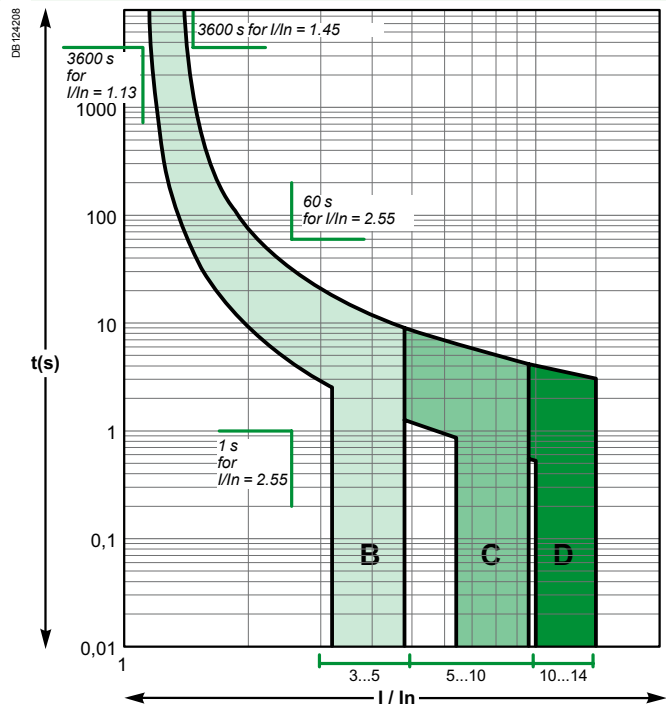

Alternative current 50/60 Hz

C60

According to IEC/EN 60898-1 (reference temperature 30°C)

Curves B, C, D

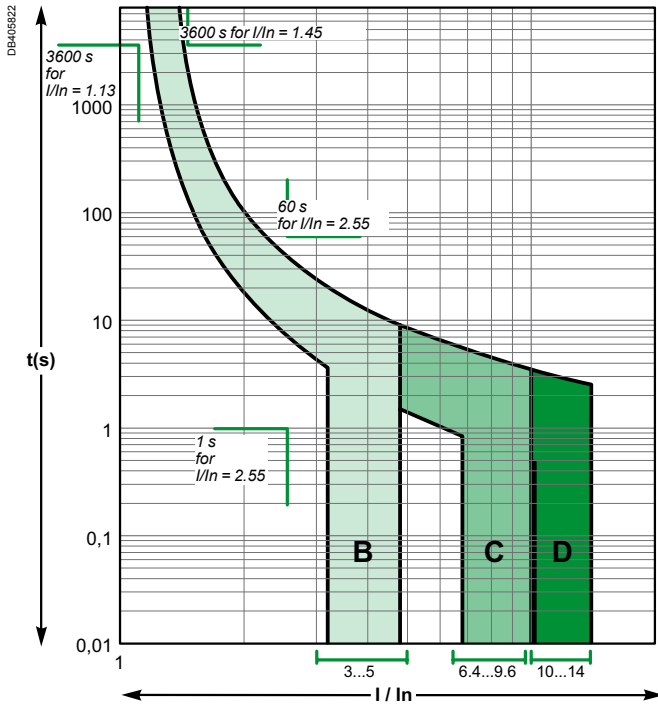

Tripping curves

According to IEC/EN 60947-2 standards

Alternative current 50/60 Hz

iC60

According to IEC/EN 60947-2 (reference temperature 50°C)

Curves B, C, D rating up to 4 A

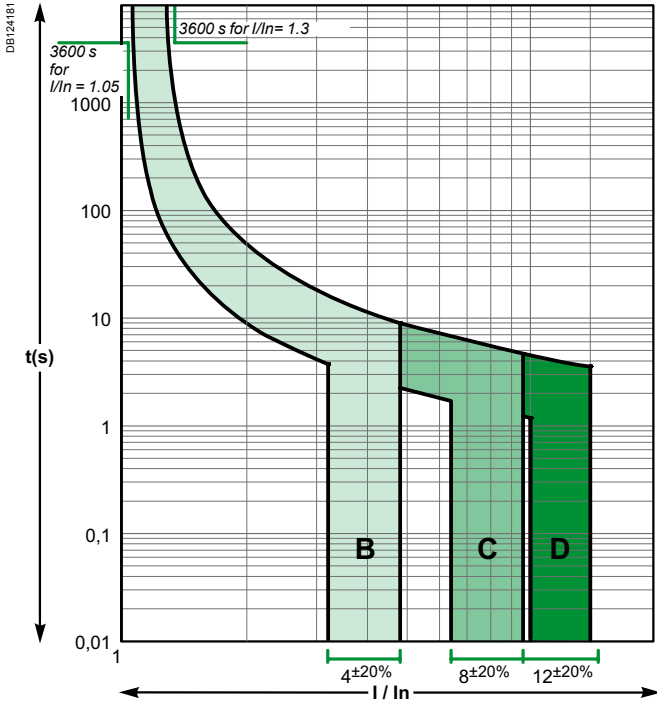

Curves Z, K rating up to 4 A

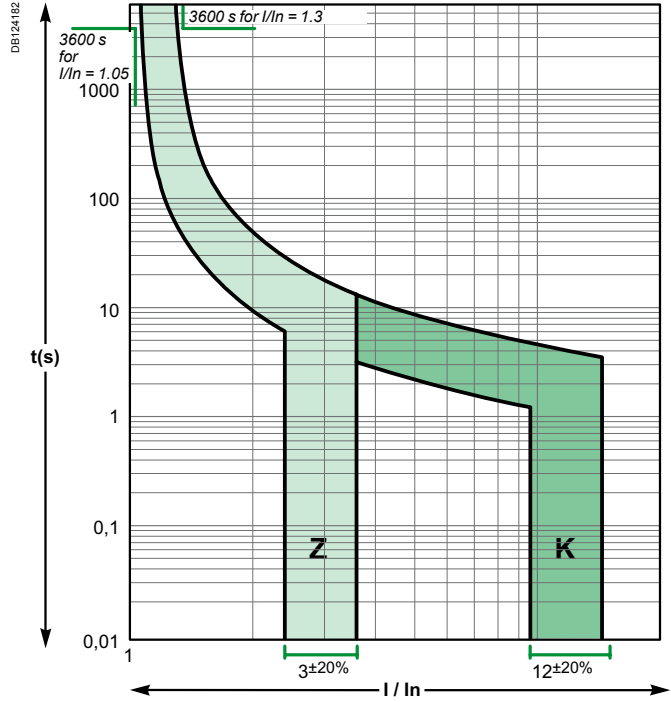

Curves B, C, D rating 6 A to 63 A

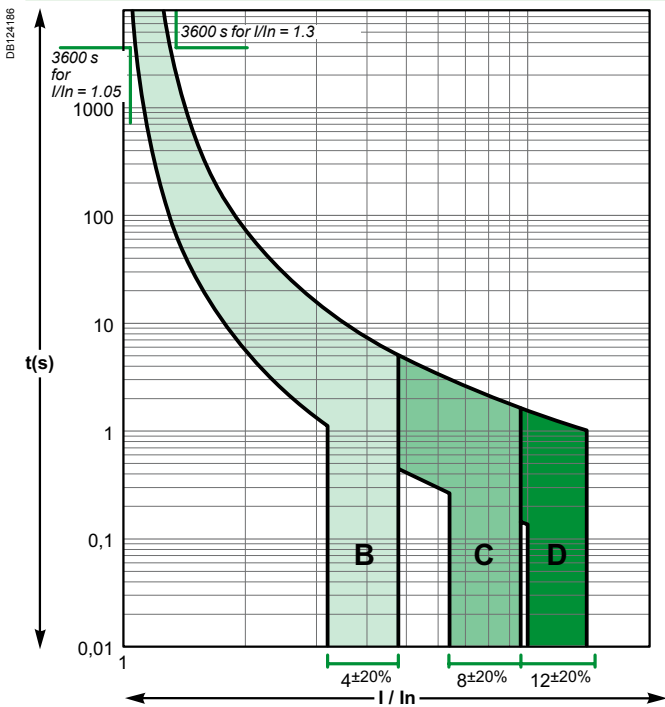

Curves Z, K rating 6 A to 63 A

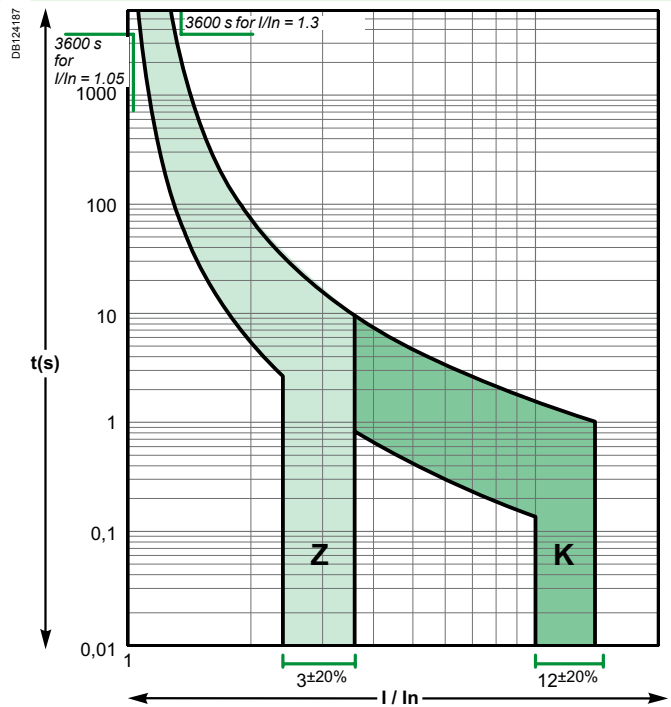

Alternative current 50/60 Hz

Reflex iC60N/H

According to IEC/EN 60947-2 (reference temperature 50°C)

Curves B, C, D

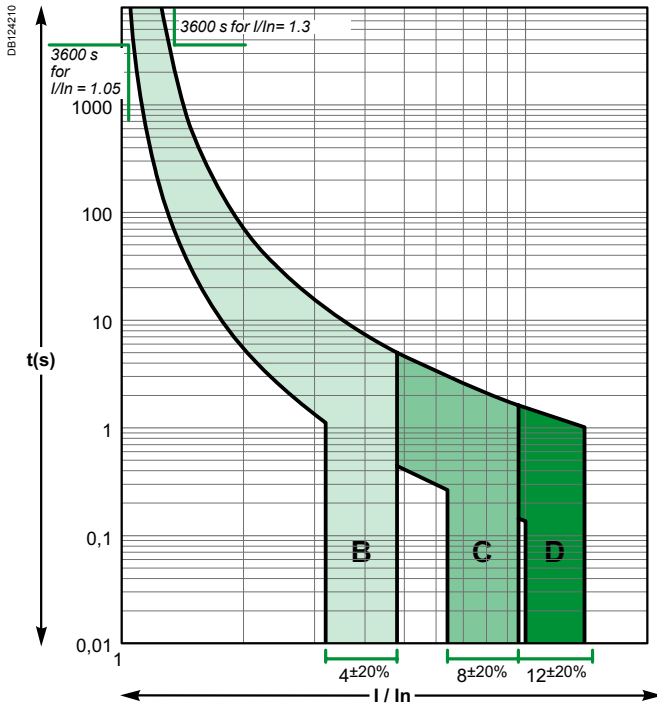

NG125a/N/H/L

According to IEC/EN 60947-2 (reference temperature 40°C)

Curves B, C, D

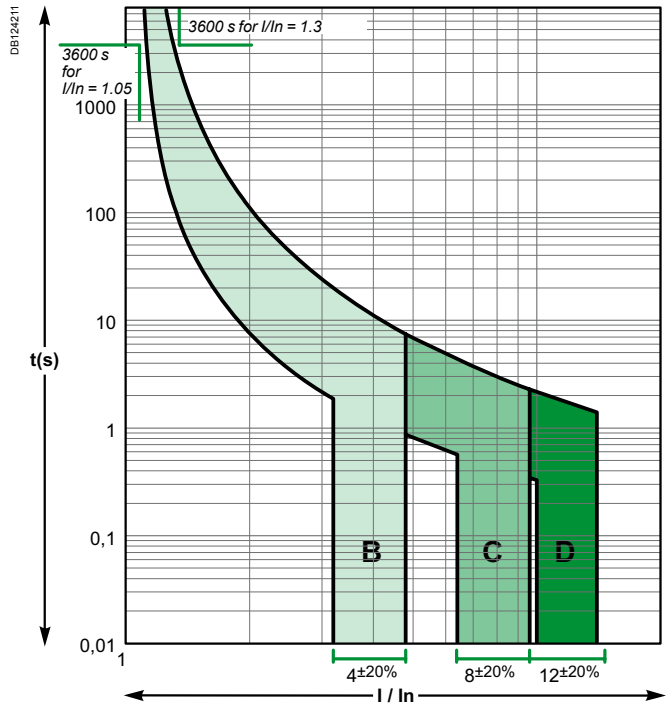

C60

According to IEC/EN 60947-2 (reference temperature 50°C)

Curves B, C, D

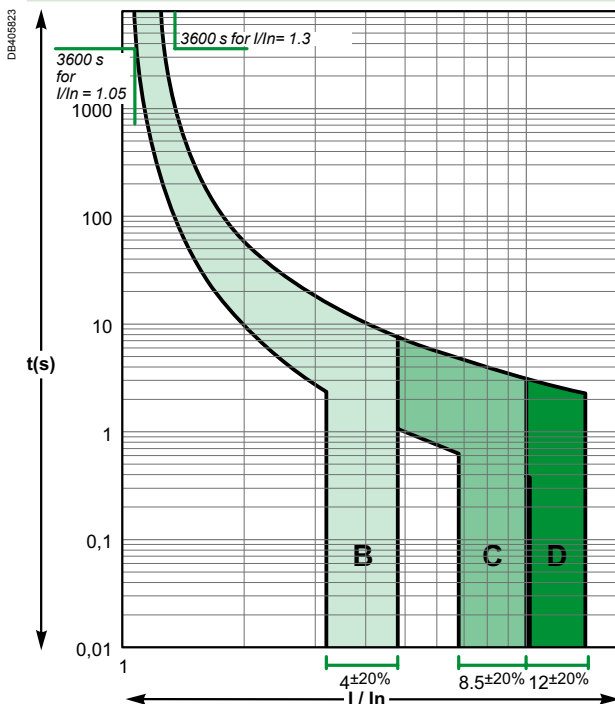

Tripping curves

According to IEC/EN 60947-2 standards

Direct current

iC60N/H/L

According to IEC/EN 60947-2 (reference temperature 50°C)

Curves B, C, D rating up to 4 A

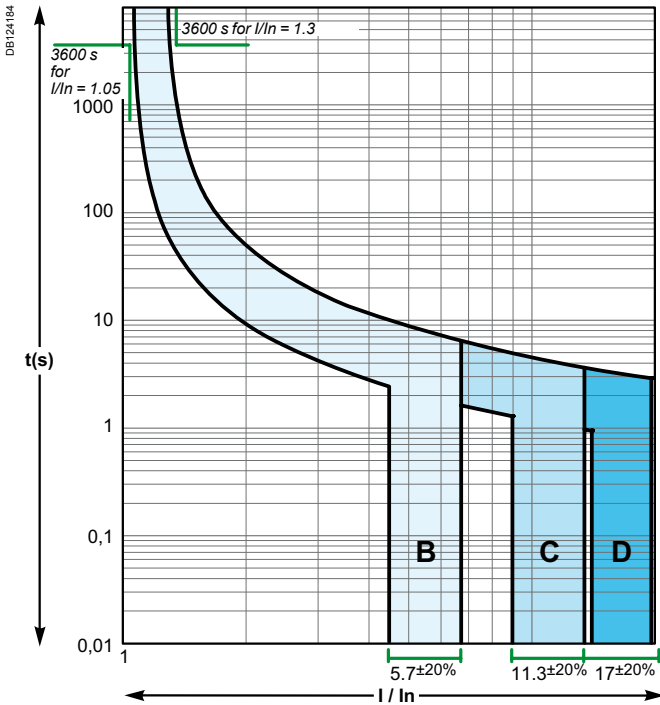

Curves Z, K rating up to 4 A

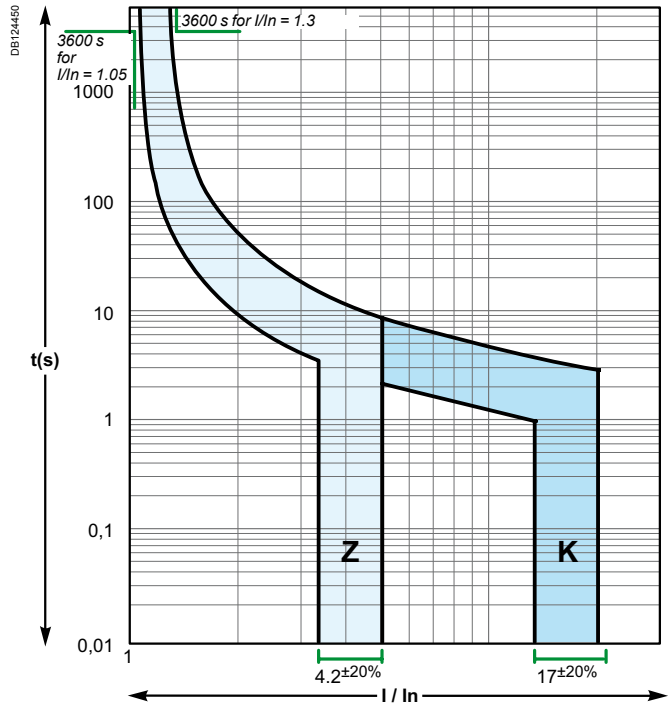

Curves B, C, D rating 6 A to 63 A

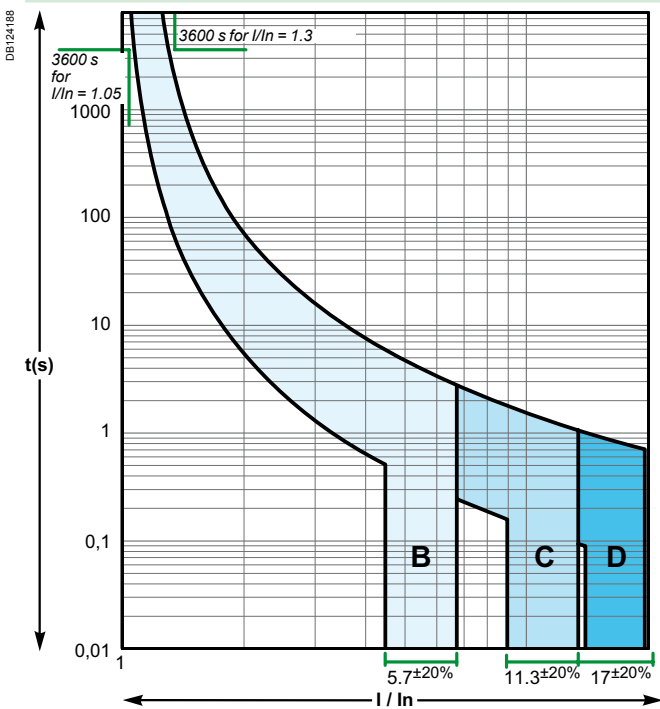

Curves Z, K rating 6 A to 63 A

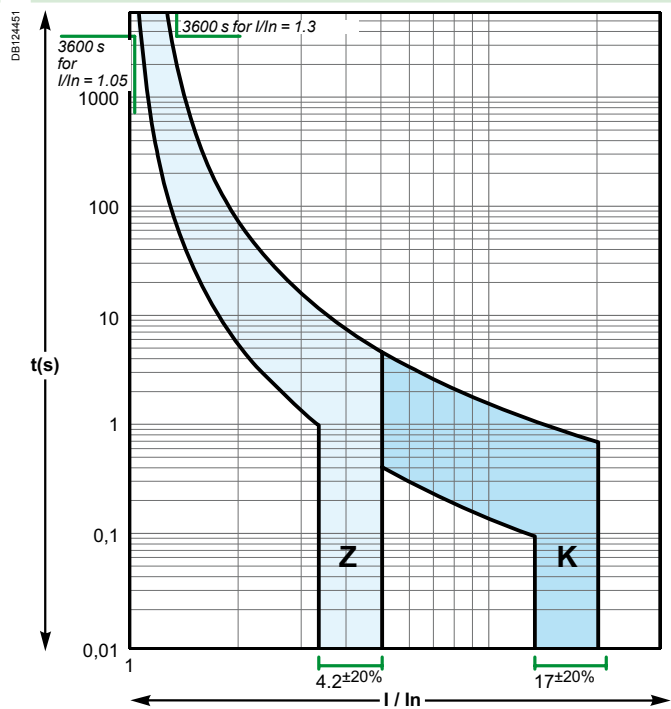

Tripping curves

According to IEC/EN 60947-2 standards

Direct current

C60H-DC

According to IEC/EN 60947-2 (reference temperature 25°C)

Curve C

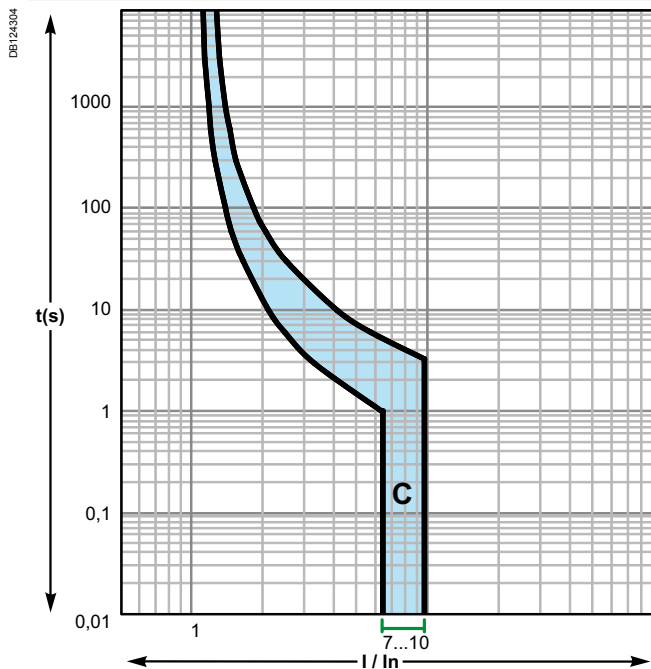

C60

According to IEC/EN 60947-2 (reference temperature 50°C)

Curves B, C, D

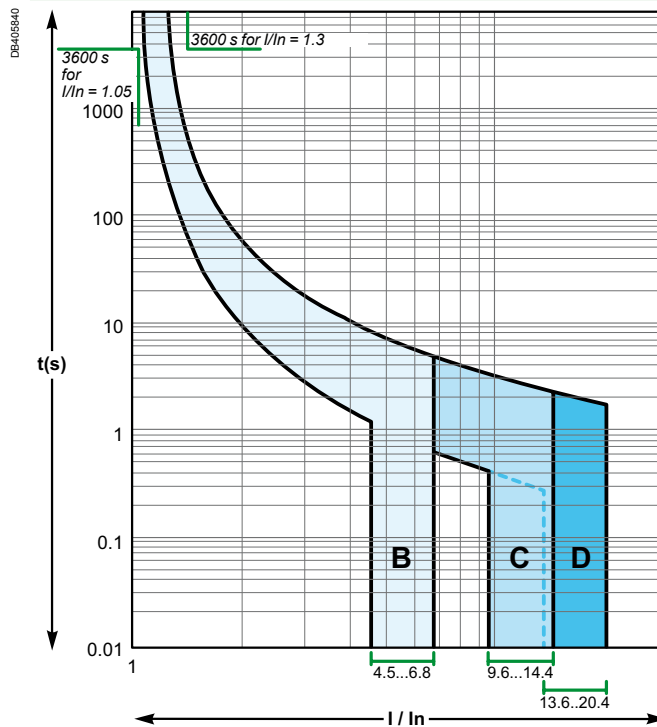

NG125a/N/H/L

According to IEC/EN 60947-2 (reference temperature 40°C)

Curves B, C, D

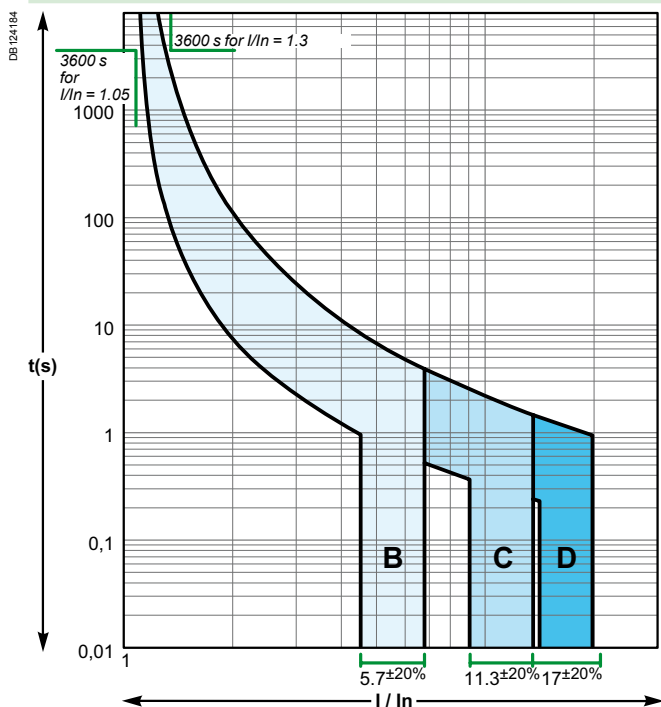

Influence of ambient temperature

Influence of temperature on the operation

Devices	Characteristics influenced by temperature	Temperature	
		Min.	Max.
DPN, C60H-DC, C60, C120, NG125, C60PV-DC circuit breakers	Tripping on overload	-30°C	+70°C
	Tripping on overload	-25°C	+60°C
iC60N circuit breakers	Tripping on overload	-35°C	+70°C
Circuit breakers	With Vigi (AC)	-5°C	+60°C
	With Vigi (A, S/I)	-25°C	+60°C
Reflex iC60	Tripping on overload	-25°C	+60°C
C60H RCBO,	Tripping on overload	-15°C	+60°C
C60NA-DC, SW60PV-DC switch-disconnectors	Maximum operating current	-25°C	+70°C
	Maximum operating current	-5°C	+60°C
iID residual current circuit breakers	AC	-5°C	+60°C
	A, S/I	-25°C	+60°C
Switches	iSW	-20°C	+50°C
	iSW-NA	-35°C	+70°C
Protection auxiliaries	None	-35°C	+70°C
RCA, ARA control auxiliaries	None	-25°C	+60°C
iCT contactors	Installation conditions	-5°C	+60°C
iTL impulse relays	None	-20°C	+50°C
iCT, iTL auxiliaries	None	-20°C	+50°C
Distribloc	Maximum operating current	-25°C	+60°C
Multiclip	Maximum operating current	-25°C	+60°C

Note: the temperature considered is the temperature viewed through the device.

Circuit breakers

High temperatures

- A rise in temperature causes lowering of the thermal threshold (tripping on overload).
 - Protection is still ensured: the tripping threshold remains lower than the current acceptable by the cable (I_z)
 - To prevent nuisance tripping, it should be checked that this threshold remains higher than the maximum operating current (I_B) of the circuit, defined by:
 - the rated load currents,
 - the coefficients of expansion and simultaneity of use.
- If the temperature is sufficiently high for the tripping threshold to become lower than the operating current I_B , switchboard ventilation should be provided for.

Low temperatures

- A fall in temperature increases the thermal tripping threshold of the circuit breaker.
- There is no risk of nuisance tripping: the threshold remains higher than the maximum operating current of the circuit (I_B) demanded by the loads.
- It should be checked that the cable remains suitably protected, i.e. that its acceptable current (I_z) is higher than the values shown in the following tables (in amperes).

When the ambient temperature could vary within a broad range, both these aspects must be taken into account:

- the difference between the maximum operating current of the circuit (I_B) and the tripping threshold of the circuit breaker for the minimum ambient temperature,
- the difference between the strength of the cable (I_z) and the maximum tripping threshold of the circuit breaker for the maximum ambient temperature.

Influence of ambient temperature (cont.)

Maximum permissible current

- The maximum current allowed to flow through the device depends on the ambient temperature in which it is placed.
- The ambient temperature is the temperature inside the enclosure or switchboard in which the devices are installed.
- The reference temperature is in a halftone colour for the different devices.

■ When several devices operating simultaneously are mounted side by side in a small enclosure, a temperature rise in the enclosure results in a reduction in the operating current. A reduction coefficient of 0.8 will then have to be assigned to the rating (already derated, if applicable, depending on the ambient temperature).

■ Example:

Depending on the ambient temperature and the method of installation, the table below shows how to determine, for an iC60, the operating currents not to be exceeded for ratings 25 A, 32 A and 40 A (reference temperature 50°C).

Operating current not to be exceeded (A)							
Installation conditions (IEC 60947-2)		iC60 alone			Several iC60 in the same enclosure (calculate with the reduction coefficient indicated below)		
Ambient temperature (°C)		35°C	50°C	65°C	35°C	50°C	65°C
Type	Nominal rating (A)	Actual rating (A)					
iC60	25	26.35	25	23.57	26.35 x 0.8 = 21	25 x 0.8 = 20	23.57 x 0.8 = 19
	32	34	32	29.9	34 x 0.8 = 27	32 x 0.8 = 25.6	29.9 x 0.8 = 24
	40	42.5	40	37.34	42.5 x 0.8 = 34	40 x 0.8 = 32	37.34 x 0.8 = 30

Influence of ambient temperature (cont.)

IEC 60898-1

C120 derating table (IEC 60898-1)

C120	Ambient temperature (°C)																				
Rating	-30	-25	-20	-15	-10	-5	0	+5	+10	+15	+20	+25	+30	+35	+40	+45	+50	+55	+60	+65	+70
10 A	12.9	12.7	12.5	12.2	12	11.8	11.5	11.3	11	10.8	10.5	10.3	10	9.7	9.4	9.1	8.8	8.5	8.2	7.9	7.5
16 A	19.4	19.1	18.8	18.6	18.3	18	17.8	17.5	17.2	16.9	16.6	16.3	16	15.7	15.4	15.1	14.7	14.4	14	13.7	13.3
20 A	24.6	24.2	23.9	23.5	23.2	22.8	22.4	22	21.6	21.2	20.8	20.4	20	19.6	19.1	18.7	18.2	17.7	17.3	16.8	16.2
25 A	30.9	30.5	30	29.5	29.1	28.6	28.1	27.6	27.1	26.6	26.1	25.5	25	24.4	23.9	23.3	22.7	22.1	21.5	20.8	20.1
32 A	38.9	38.4	37.9	37.3	36.8	36.2	35.6	35	34.5	33.9	33.3	32.6	32	31.4	30.7	30	29.3	28.6	27.9	27.2	26.4
40 A	49.8	49.1	48.3	47.6	46.8	46	45.2	44.4	43.5	42.7	41.8	40.9	40	39.1	38.1	37.1	36.1	35.1	34.1	33	31.8
50 A	62.2	61.3	60.4	59.4	58.4	57.5	56.5	55.4	54.4	53.3	52.2	51.1	50	48.8	47.7	46.4	45.2	43.9	42.6	41.2	39.8
63 A	78.6	77.5	76.3	75	73.8	72.5	71.3	69.9	68.6	67.3	65.9	64.5	63	61.5	60	58.4	56.8	55.2	53.5	51.7	49.9
80 A	98.4	97	95.6	94.2	92.7	91.2	89.7	88.1	86.6	85	83.4	81.7	80	78.3	76.5	74.7	72.8	70.9	69	67	64.9
100 A	124.5	122.6	120.7	118.8	116.9	114.9	112.9	110.9	108.8	106.6	104.5	102.3	100	97.7	95.3	92.9	90.4	87.8	85.2	82.5	79.6
125 A	157	154.6	152.2	149.7	147.1	144.6	141.9	139.2	136.5	133.7	130.9	128	125	122	118.8	115.6	112.3	108.9	105.4	101.8	98

Influence of ambient temperature (cont.)

Tertiary/Industry (IEC 60947-2)

DPN derating table (IEC 60947-2)

DPN		Ambient temperature (°C)																				
Rating	Curve	-30	-25	-20	-15	-10	-5	0	+5	+10	+15	+20	+25	+30	+35	+40	+45	+50	+55	+60	+65	+70
1 A	B, C, D	1.69	1.66	1.62	1.59	1.55	1.51	1.47	1.43	1.39	1.35	1.3	1.26	1.21	1.16	1.11	1.06	1	0.94	0.88	0.81	0.73
2 A	B, C, D	2.68	2.64	2.6	2.56	2.52	2.48	2.44	2.4	2.36	2.32	2.28	2.23	2.19	2.14	2.1	2.05	2	1.95	1.9	1.85	1.79
3 A	B, C, D	4.03	3.97	3.91	3.86	3.8	3.74	3.68	3.61	3.55	3.49	3.42	3.36	3.29	3.22	3.15	3.07	3	2.92	2.85	2.77	2.68
4 A	B, C, D	5.26	5.19	5.12	5.05	4.98	4.9	4.83	4.75	4.67	4.6	4.52	4.43	4.35	4.27	4.18	4.09	4	3.91	3.81	3.72	3.62
6 A	B, C, D	7.51	7.42	7.34	7.25	7.16	7.07	6.98	6.89	6.8	6.7	6.61	6.51	6.41	6.31	6.21	6.11	6	5.89	5.78	5.67	5.56
10 A	B	12.5	12.3	12.2	12.1	11.9	11.8	11.6	11.5	11.3	11.2	11	10.8	10.7	10.5	10.3	10.2	10	9.8	9.7	9.5	9.3
10 A	C, D	13	12.9	12.7	12.5	12.3	12.2	12	11.8	11.6	11.4	11.2	11	10.8	10.6	10.4	10.2	10	9.8	9.6	9.3	9.1
13 A	B	17	16.7	16.5	16.3	16.1	15.8	15.6	15.4	15.1	14.9	14.6	14.4	14.1	13.8	13.6	13.3	13	12.7	12.4	12.1	11.8
13 A	C, D	17.2	16.9	16.7	16.5	16.2	16	15.7	15.5	15.2	15	14.7	14.4	14.2	13.9	13.6	13.3	13	12.7	12.4	12.1	11.7
16 A	B, C	20.6	20.4	20.1	19.8	19.6	19.3	19	18.7	18.5	18.2	17.9	17.6	17.3	17	16.7	16.3	16	15.7	15.3	15	14.6
16 A	D	20.8	20.5	20.2	20	19.7	19.4	19.1	18.8	18.5	18.2	17.9	17.6	17.3	17	16.7	16.3	16	15.7	15.3	14.9	14.6
20 A	B	25.7	25.3	25	24.7	24.4	24	23.7	23.4	23	22.7	22.3	21.9	21.6	21.2	20.8	20.4	20	19.6	19.2	18.8	18.3
20 A	C, D	26	25.7	25.3	25	24.6	24.3	23.9	23.6	23.2	22.8	22.4	22	21.7	21.3	20.8	20.4	20	19.6	19.1	18.7	18.2
25 A	B, C, D	32	31.6	31.2	30.8	30.4	30	29.6	29.2	28.7	28.3	27.8	27.4	26.9	26.5	26	25.5	25	24.5	24	23.5	22.9
32 A	B, C, D	41.6	41.1	40.5	40	39.4	38.9	38.3	37.7	37.1	36.5	35.9	35.3	34.7	34	33.4	32.7	32	31.3	30.6	29.9	29.1
40 A	B, C, D	52.7	52	51.3	50.6	49.8	49.1	48.3	47.6	46.8	46	45.2	44.4	43.5	42.7	41.8	40.9	40	39.1	38.1	37.1	36.1

iC60, Reflex iC60 derating table (IEC 60947-2)

iC60		Ambient temperature (°C)																					
Rating		-35	-30	-25	-20	-15	-10	-5	0	+5	+10	+15	+20	+25	+30	+35	+40	+45	+50	+55	+60	+65	+70
0.5 A		0.66	0.65	0.64	0.63	0.63	0.62	0.61	0.6	0.59	0.58	0.57	0.56	0.55	0.54	0.53	0.52	0.51	0.5	0.49	0.48	0.47	0.45
1 A		1.32	1.3	1.28	1.27	1.25	1.23	1.21	1.2	1.18	1.16	1.14	1.12	1.1	1.08	1.06	1.04	1.02	1	0.98	0.96	0.93	0.91
2 A		2.79	2.75	2.71	2.67	2.63	2.58	2.54	2.5	2.45	2.4	2.36	2.31	2.26	2.21	2.16	2.11	2.05	2	1.94	1.89	1.83	1.76
3 A		4.21	4.15	4.08	4.02	3.96	3.89	3.83	3.76	3.69	3.62	3.55	3.48	3.4	3.32	3.25	3.17	3.08	3	2.91	2.82	2.73	2.64
4 A		5.62	5.54	5.46	5.37	5.29	5.2	5.11	5.02	4.93	4.83	4.74	4.64	4.54	4.44	4.33	4.22	4.11	4	3.88	3.76	3.64	3.51
6 A		8.55	8.42	8.29	8.16	8.03	7.89	7.75	7.61	7.46	7.31	7.16	7.01	6.85	6.69	6.52	6.35	6.18	6	5.81	5.62	5.43	5.22
10 A		13.3	13.2	13	12.8	12.6	12.5	12.3	12.1	11.9	11.7	11.5	11.3	11.1	10.9	10.7	10.5	10.2	10	9.8	9.5	9.3	9
13 A		17.1	16.9	16.7	16.4	16.2	16	15.8	15.5	15.3	15.1	14.8	14.6	14.3	14.1	13.8	13.6	13.3	13	12.7	12.4	12.1	11.8
16 A		21.1	20.8	20.6	20.3	20	19.7	19.5	19.2	18.9	18.6	18.3	18	17.7	17.3	17	16.7	16.3	16	15.7	15.3	14.9	14.5
20 A		26	25.7	25.4	25	24.7	24.4	24.1	23.7	23.4	23	22.7	22.3	21.9	21.6	21.2	20.8	20.4	20	19.6	19.2	18.7	18.3
25 A		31.9	31.6	31.2	30.8	30.4	30.1	29.7	29.3	28.9	28.5	28.1	27.6	27.2	26.8	26.4	25.9	25.5	25	24.5	24.1	23.6	23.1
32 A		42	41.5	41	40.5	39.9	39.4	38.8	38.2	37.7	37.1	36.5	35.9	35.3	34.6	34	33.3	32.7	32	31.3	30.6	29.9	29.1
40 A		52.6	51.9	51.3	50.6	49.9	49.2	48.5	47.8	47.1	46.4	45.6	44.9	44.1	43.3	42.5	41.7	40.9	40	39.1	38.2	37.3	36.4
50 A		67.1	66.3	65.4	64.5	63.5	62.6	61.6	60.7	59.7	58.7	57.7	56.7	55.6	54.5	53.4	52.3	51.2	50	48.8	47.6	46.3	45
63 A		86.3	85.1	83.9	82.7	81.4	80.1	78.9	77.6	76.2	74.9	73.5	72.1	70.7	69.2	67.7	66.2	64.6	63	61.4	59.7	57.9	56.1

Reflex iC60

C60 derating table (IEC 60947-2)

C60		Ambient temperature (°C)																				
Rating		-30	-25	-20	-15	-10	-5	0	+5	+10	+15	+20	+25	+30	+35	+40	+45	+50	+55	+60	+65	+70
0.5 A		0.68	0.67	0.66	0.65	0.64	0.63	0.62	0.61	0.6	0.59	0.58	0.56	0.55	0.54	0.53	0.51	0.5	0.49	0.47	0.46	0.44
0.75 A		0.93	0.92	0.91	0.9	0.89	0.88	0.87	0.86	0.85	0.83	0.82	0.81	0.8	0.79	0.78	0.76	0.75	0.74	0.72	0.7	0.68
1 A		1.31	1.3	1.28	1.27	1.25	1.23	1.21	1.19	1.17	1.15	1.13	1.11	1.09	1.07	1.05	1.02	1	0.98	0.95	0.93	0.91
2 A		2.55	2.59	2.56	2.52	2.49	2.45	2.41	2.37	2.34	2.3	2.26	2.22	2.17	2.13	2.09	2.04	2	1.95	1.91	1.88	1.84
3 A		3.81	4.04	3.98	3.92	3.85	3.79	3.73	3.66	3.59	3.52	3.45	3.38	3.31	3.23	3.16	3.08	3	2.92	2.83	2.82	2.76
4 A		4.9	4.86	4.81	4.76	4.7	4.65	4.59	4.54	4.48	4.42	4.37	4.31	4.25	4.19	4.13	4.06	4	3.94	3.87	3.81	3.74
6 A		7.93	7.82	7.71	7.6	7.49	7.38	7.27	7.15	7.03	6.91	6.79	6.66	6.54	6.41	6.27	6.14	6	5.86	5.71	5.56	5.42
8 A		10.37	10.23	10.09	9.96	9.82	9.68	9.54	9.4	9.25	9.11	8.96	8.81	8.65	8.49	8.33	8.17	8	7.83	7.65	7.47	7.31
10 A		13.3	13.2	13	12.8	12.6	12.4	12.2	12	11.8	11.6	11.4	11.2	10.9	10.7	10.5	10.2	10	9.8	9.5	9.2	9
13 A		17	16.9	16.6	16.4	16.2	15.9	15.7	15.4	15.2	14.9	14.7	14.4	14.1	13.9	13.6	13.3	13	12.7	12.4	12.1	11.8
16 A		20	19.8	19.5	19.3	19.1	18.8	18.6	18.4	18.1	17.9	17.6	17.3	17.1	16.8	16.6	16.3	16	15.7	15.4	15.1	14.8
20 A		26.9	26.6	26.2	25.8	25.4	25	24.6	24.2	23.7	23.3	22.9	22.4	22	21.5	21	20.5	20	19.5	18.9	18.4	17.9
25 A		32.9	32.5	32.1	31.6	31.1	30.7	30.2	29.7	29.2	28.7	28.2	27.7	27.2	26.7	26.1	25.6	25	24.4	23.8	23.2	22.6
32 A		41.5	41.1	40.5	40	39.4	38.9	38.3	37.7	37.1	36.5	35.9	35.3	34.7	34	33.4	32.7	32	31.3	30.6	29.9	29.1
40 A		53.7	52.9	52.2	51.4	50.6	49.8	49	48.2	47.3	46.5	45.6	44.7	43.8	42.9	42	41	40	39	37.9	36.9	35.8
45 A		60.8	60.1	59.2	58.3	57.4	56.5	55.5	54.6	53.6	52.6	51.6	50.5	49.5	48.4	47.3	46.2	45	43.8	42.6	41.4	40.1
50 A		65	64.3	63.5	62.6	61.7	60.8	59.9	59	58.1	57.1	56.2	55.2	54.2	53.2	52.1	51.1	50	48.9	47.8	46.7	45.5
63 A		85.5	84.6	83.3	82	80.7	79.4	78	76.7	75.3	73.9	72.4	70.9	69.4	67.9	66.3	64.7	63	61.3	59.5	57.8	56

Influence of ambient temperature (cont.)

Tertiary/Industry (IEC 60947-2) (cont.)

C60H-DC derating table (IEC 60947-2)

C60H-DC	Ambient temperature (°C)																				
Rating	-30	-25	-20	-15	-10	-5	0	+5	+10	+15	+20	+25	+30	+35	+40	+45	+50	+55	+60	+65	+70
0.5A	0.63	0.62	0.61	0.6	0.59	0.58	0.56	0.55	0.54	0.53	0.51	0.5	0.49	0.47	0.46	0.44	0.43	0.41	0.39	0.38	0.36
1A	1.18	1.17	1.15	1.14	1.12	1.1	1.09	1.07	1.05	1.04	1.02	1	0.98	0.96	0.94	0.92	0.9	0.88	0.86	0.84	0.82
2A	2.54	2.5	2.45	2.41	2.36	2.31	2.26	2.21	2.16	2.11	2.06	2	1.94	1.88	1.82	1.76	1.7	1.63	1.56	1.48	1.41
3A	3.78	3.71	3.65	3.58	3.51	3.45	3.38	3.3	3.23	3.16	3.08	3	2.92	2.84	2.75	2.66	2.57	2.48	2.38	2.27	2.17
4A	5.08	4.99	4.9	4.81	4.71	4.62	4.52	4.42	4.32	4.22	4.11	4	3.89	3.77	3.65	3.53	3.4	3.27	3.13	2.98	2.83
5A	6	5.92	5.83	5.74	5.66	5.57	5.48	5.39	5.29	5.2	5.1	5	4.9	4.8	4.69	4.58	4.47	4.36	4.24	4.12	4
6A	7.26	7.15	7.04	6.94	6.83	6.71	6.6	6.48	6.37	6.25	6.12	6	5.87	5.74	5.61	5.47	5.33	5.19	5.04	4.89	4.73
10A	12.6	12.4	12.2	11.9	11.7	11.5	11.3	11	10.8	10.5	10.3	10	9.7	9.5	9.2	8.9	8.6	8.3	7.9	7.6	7.2
13A	15.5	15.3	15.1	14.9	14.6	14.4	14.2	14	13.7	13.5	13.3	13	12.8	12.5	12.2	12	11.7	11.4	11.1	10.8	10.5
15A	18.6	18.3	18	17.7	17.4	17.1	16.7	16.4	16.1	15.7	15.4	15	14.6	14.3	13.9	13.5	13	12.6	12.2	11.7	11.2
16A	19.4	19.1	18.9	18.6	18.3	18	17.6	17.3	17	16.7	16.3	16	15.7	15.3	14.9	14.6	14.2	13.8	13.4	13	12.5
20A	24.1	23.7	23.4	23	22.7	22.3	21.9	21.6	21.2	20.8	20.4	20	19.6	19.2	18.7	18.3	17.9	17.4	16.9	16.4	15.9
25A	30.4	29.9	29.5	29	28.5	28.1	27.6	27.1	26.6	26.1	25.5	25	24.5	23.9	23.3	22.7	22.1	21.5	20.9	20.2	19.6
30A	37.4	36.7	36.1	35.5	34.9	34.2	33.5	32.9	32.2	31.5	30.7	30	29.2	28.5	27.7	26.8	26	25.1	24.2	23.2	22.3
32A	38.5	37.9	37.4	36.8	36.2	35.7	35.1	34.5	33.9	33.3	32.6	32	31.4	30.7	30	29.3	28.6	27.9	27.1	26.3	25.5
40A	48.9	48.2	47.4	46.7	45.9	45.1	44.3	43.5	42.6	41.8	40.9	40	39.1	38.2	37.2	36.2	35.2	34.2	33.1	32	30.8
50A	59.9	59.1	58.3	57.4	56.5	55.6	54.7	53.8	52.9	52	51	50	49	48	46.9	45.9	44.8	43.6	42.5	41.3	40.1
63A	78.2	76.9	75.6	74.3	73	71.7	70.3	68.9	67.5	66	64.5	63	61.4	59.8	58.2	56.5	54.7	52.9	51.1	49.1	47.1

C60PV-DC derating table (IEC 60947-2)

C60PV-DC	Ambient temperature (°C)																				
Rating	-30	-25	-20	-15	-10	-5	0	+5	+10	+15	+20	+25	+30	+35	+40	+45	+50	+55	+60	+65	+70
1A	1.18	1.17	1.15	1.14	1.12	1.1	1.09	1.07	1.05	1.04	1.02	1	0.98	0.96	0.94	0.92	0.9	0.88	0.86	0.84	0.82
2A	2.54	2.5	2.45	2.41	2.36	2.31	2.26	2.21	2.16	2.11	2.06	2	1.94	1.88	1.82	1.76	1.7	1.63	1.56	1.48	1.41
3A	3.78	3.71	3.65	3.58	3.51	3.45	3.38	3.3	3.23	3.16	3.08	3	2.92	2.84	2.75	2.66	2.57	2.48	2.38	2.27	2.17
5A	6	5.92	5.83	5.74	5.66	5.57	5.48	5.39	5.29	5.2	5.1	5	4.9	4.8	4.69	4.58	4.47	4.36	4.24	4.12	4
8A	9.64	9.5	9.36	9.22	9.08	8.93	8.78	8.63	8.48	8.32	8.16	8	7.83	7.67	7.49	7.31	7.13	6.95	6.76	6.56	6.36
10A	12.6	12.4	12.2	11.9	11.7	11.5	11.2	11	11.8	10.5	10.3	10	9.7	9.4	9.2	9.9	8.6	8.2	7.9	7.6	7.2
13A	15.5	15.3	15.1	14.8	14.6	14.4	14.2	14	13.7	13.5	13.2	13	12.7	12.5	12.2	12	11.7	11.4	11.1	10.8	10.5
15A	18.6	18.3	18	17.7	17.4	17.1	16.7	16.4	16.1	16.7	15.4	15	14.6	14.3	13.9	13.5	13	12.6	12.2	11.7	11.2
16A	19.4	19.1	18.9	18.6	18.3	18	17.6	17.3	17	16.7	16.3	16	15.7	15.3	14.9	14.6	14.2	13.8	13.4	13	12.5
20A	24.1	23.7	23.4	23	22.7	22.3	21.9	21.6	21.2	20.8	20.4	20	19.6	19.2	18.7	18.3	17.9	17.4	16.9	16.4	15.9
25A	30.4	29.9	29.5	29	28.5	28.1	27.6	27.1	26.6	26.1	25.5	25	24.5	23.9	23.3	22.7	22.1	21.5	20.9	20.2	19.6
30A	37.4	36.7	36.1	35.5	34.9	34.2	33.5	32.9	32.2	31.5	30.7	30	29.2	28.5	27.7	26.8	26	25.1	24.2	23.2	22.3

C120 derating table (IEC 60947-2)

C120	Ambient temperature (°C)																				
Rating	-30	-25	-20	-15	-10	-5	0	+5	+10	+15	+20	+25	+30	+35	+40	+45	+50	+55	+60	+65	+70
10A	14.5	14.3	14	13.8	13.5	13.3	13	12.7	12.5	12.2	11.9	11.6	11.3	11	10.7	10.3	10	9.7	9.3	8.9	8.5
16A	21.2	21	20.7	20.4	20.1	19.8	19.4	19.1	18.8	18.5	18.2	17.8	17.5	17.1	16.8	16.4	16	15.6	15.2	14.8	14.4
20A	27	26.6	26.3	25.9	25.5	25	24.6	24.2	23.8	23.3	22.9	22.4	22	21.5	21	20.5	20	19.5	18.9	18.4	17.8
25A	33.7	33.3	32.8	32.3	31.8	31.3	30.8	30.2	29.7	29.1	28.6	28	27.5	26.9	26.3	25.6	25	24.4	23.7	23	22.3
32A	42.7	42.1	41.5	40.9	40.3	39.7	39	38.4	37.7	37.1	36.4	35.7	35	34.3	33.5	32.8	32	31.2	30.4	29.6	28.7
40A	54.8	54	53.2	52.4	51.5	50.7	49.8	48.9	48	47.1	46.1	45.2	44.2	43.2	42.1	41.1	40	38.9	37.7	36.6	35.3
50A	69.1	68.1	67	65.9	64.8	63.7	62.6	61.5	60.3	59.1	57.9	56.7	55.4	54.1	52.8	51.4	50	48.6	47.1	45.5	43.9
63A	87.1	85.8	84.5	83.1	81.8	80.4	78.9	77.5	76	74.5	73	71.4	69.8	68.2	66.5	64.8	63	61.2	59.3	57.4	55.4
80A	103.7	102.4	101	99.7	98.3	96.9	95.5	94.1	92.6	91.1	89.6	88.1	86.5	84.9	83.3	81.7	80	78.3	76.5	74.7	72.9
100A	137.6	135.5	133.5	131.4	129.2	127.1	124.8	122.6	120.3	118	115.6	113.1	110.6	108.1	105.5	102.8	100	97.2	94.2	91.2	88.1
125A	174.6	171.9	169.2	166.4	163.6	160.7	157.8	154.9	151.8	148.7	145.6	142.4	139.1	135.7	132.2	128.7	125	121.2	117.3	113.3	109.1

Influence of ambient temperature (cont.)

Tertiary/Industry (IEC 60947-2) (cont.)

NG125 derating table (IEC 60947-2)

NG125	Ambient temperature (°C)																				
Rating	-30	-25	-20	-15	-10	-5	0	+5	+10	+15	+20	+25	+30	+35	+40	+45	+50	+55	+60	+65	+70
10 A	13.7	13.5	13.2	13	12.8	12.5	12.3	12	11.7	11.5	11.2	10.9	10.6	10.3	10	9.7	9.4	9	8.7	8.3	7.9
16 A	20.3	20.1	19.8	19.5	19.2	18.9	18.6	18.3	18	17.7	17.4	17	16.7	16.4	16	15.7	15.3	14.9	14.5	14.1	13.7
20 A	26	25.6	25.3	24.9	24.5	24	23.6	23.2	22.8	22.3	21.9	21.4	21	20.5	20	19.5	19	18.5	17.9	17.4	16.8
25 A	33.8	33.2	32.7	32.1	31.5	30.9	30.3	29.7	29.1	28.4	27.8	27.1	26.4	25.7	25	24.3	23.5	22.7	21.9	21	20.1
32 A	41.2	40.6	40	39.4	38.8	38.2	37.5	36.9	36.2	35.6	34.9	34.2	33.5	32.7	32	31.2	30.5	29.7	28.8	28	27.1
40 A	53.5	52.7	51.8	51	50.1	49.1	48.2	47.3	46.3	45.3	44.3	43.3	42.2	41.1	40	38.9	37.7	36.5	35.2	33.9	32.5
50 A	66.3	65.2	64.2	63.1	62.1	61	59.8	58.7	57.5	56.4	55.1	53.9	52.6	51.3	50	48.6	47.2	45.8	44.3	42.7	41.1
63 A	83.4	82.1	80.8	79.5	78.1	76.8	75.4	73.9	72.5	71	69.5	67.9	66.3	64.7	63	61.3	59.5	57.7	55.8	53.9	51.8
80 A	100.4	99.1	97.8	96.4	95	93.6	92.2	90.8	89.3	87.8	86.3	84.8	83.2	81.6	80	78.3	76.6	74.9	73.1	71.3	69.4
100 A	133.4	131.3	129.1	127	124.8	122.5	120.2	117.9	115.5	113.1	110.6	108	105.4	102.7	100	97.2	94.3	91.3	88.2	85	81.6
125 A	165.2	162.7	160.1	157.5	154.8	152.1	149.3	146.5	143.6	140.7	137.7	134.6	131.5	128.3	125	121.6	118.1	114.6	110.9	107	103.1

Tertiary/Industry (IEC 60947-3)

SW60-DC derating table (IEC 60947-3)

SW60PV-DC	Ambient temperature (°C)											
Rating	+5	+10	+15	+20	+25	+30	+35	+40	+45	+50	+60	+70
50 A	63	61	60	58	56	54	52	50	48	46	41	35

C60H RCBO derating table (IEC 61009-1)

C60H RCBO	Ambient temperature (°C)															
Rating	-15	-10	-5	0	+5	+10	+15	+20	+25	+30	+35	+40	+45	+50	+55	+60
6 A	8.3	8.15	7.99	7.83	7.67	7.50	7.33	7.16	6.98	6.79	6.6	6.41	6.21	6	5.78	5.56
10 A	12.9	12.7	12.5	12.3	12.1	11.9	11.6	11.4	11.2	11	10.7	10.5	10.3	10	9.7	9.5
16 A	20.9	20.6	20.3	19.9	19.6	19.2	18.8	18.4	18.1	17.7	17.3	16.9	16.4	16	15.6	15.1
20 A	26.3	25.9	25.4	25	24.5	24.1	23.6	23.1	22.6	22.1	21.6	21.1	20.6	20	19.4	18.8
25 A	31.5	31	30.6	30.1	29.6	29.2	28.7	28.2	27.7	27.2	26.6	26.1	25.6	25	24.4	23.8
32 A	39.2	38.7	38.2	37.7	37.2	36.6	36.1	35.5	35	34.4	33.8	33.2	32.6	32	31.4	30.7
40 A	50.2	49.5	48.8	48	47.3	46.5	45.8	45	44.2	43.4	42.6	41.7	40.9	40	39.1	38.2
45 A	55.5	54.7	54	53.2	52.5	51.7	50.9	50.1	49.3	48.5	47.6	46.8	45.9	45	41.9	41

Influence of ambient temperature (cont.)

Switches

■ In all cases, the switches are correctly protected against overloads by a circuit breaker with a lower or equal rating, operating at the same ambient temperature.

iCT contactors

In the case of contactor mounting in an enclosure for which the interior temperature is in a range between 50°C and 60°C, it is necessary to use a spacer, cat. no. A9A27062, between each contactor.

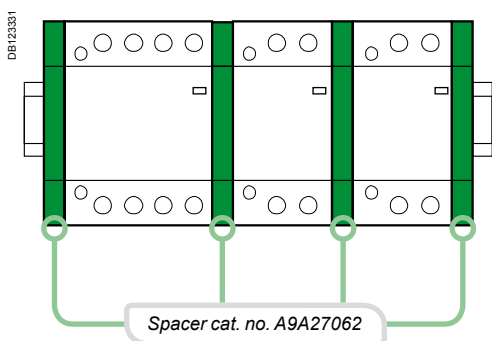

Splitter blocks

In the event of a temperature higher than 40°C, the maximum acceptable current is limited to the values in the table below:

Type	Temperature				
	40°C	45°C	50°C	55°C	60°C
Multiclip 80 A	80	76	73	69	66
Distribloc 63 A	63	60	58	55	53

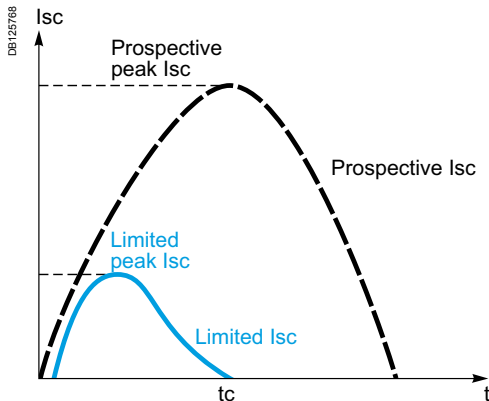

Prospective current and real limit current.

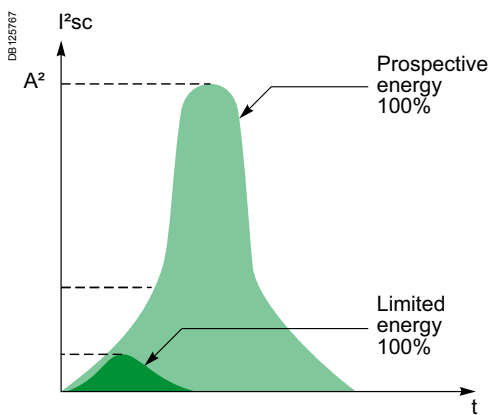

Definition

The limiting capacity of a circuit breaker is its ability to lessen the effects of a short circuit on an electrical installation by reducing the current amplitude and the dissipated power.

Benefits of limiting

Long installation service life

Thermal effects

Lower temperature rise at the conductor level, hence increased service life for cables and all components that are not self-protected (e.g. switches, contactors, etc.)

Mechanical effects

Lower electrodynamic repulsion forces, hence less risk of deformation or breakage of electrical contacts and busbars.

Electromagnetic effects

Less interference on sensitive equipment located in the vicinity of an electric circuit.

Savings through cascading

Cascading is a technique derived directly from current limiting: downstream of a current-limiting circuit breaker it is possible to use circuit breakers of breaking capacity lower than the prospective short-circuit current (in line with the cascading tables). The breaking capacity is heightened thanks to current limiting by the upstream device. Substantial savings can be achieved in this way on switchgear and enclosures.

Discrimination of protection devices

The circuit breakers' current limiting capacity improves discrimination with the protection devices located upstream: this is because the required energy passing through the upstream protection device is greatly reduced and can be not enough to cause it to trip. Discrimination can thus be natural without having to install a time-delayed protection device upstream.

Acti 9 circuit breaker current limiting

Profiting from Schneider Electric's experience and expertise in the field of short-circuit current breaking, the circuit breakers of the Acti 9 range have a top-level current limiting characteristic for modular devices.

This assures them of optimal protection of the entire power distribution system.

Short-circuit current limiting (cont.)

Representation: Current limiting curves

The current limiting capacity of a circuit breaker is reflected by 2 curves which give, as a function of the prospective short-circuit current (current which would flow in the absence of a protection device):

- the real peak current (limited)
- the thermal stress (in A²s), this value, multiplied by the resistance of any element through which the short-circuit current passes, gives the power dissipated by this element.

The straight line "10 ms" representing the energy A²s of a prospective short-circuit current of a half-period (10 ms) indicates the energy that would be dissipated by the short-circuit current in the absence of limiting by the protection device (see example).

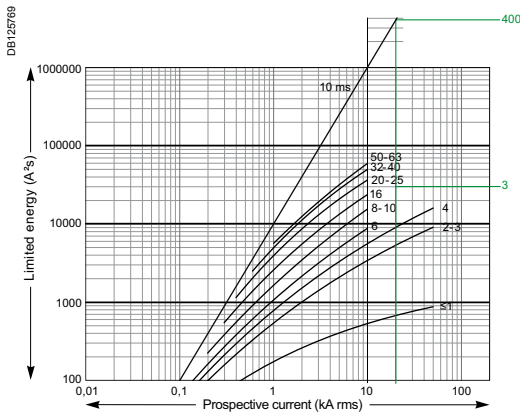

Example

What is the energy limited by an iC60N 25 A circuit breaker for a prospective short-circuit current of 10 kA rms. What is the quality of current limiting?

> as shown in the graph opposite:

- this short-circuit current (10 kA rms) is likely to dissipate up to 1,000 kA²s
- the iC60N circuit breaker reduces this thermal stress to: 35 kA²s, which is 22 times less.

Example of use: Stresses acceptable by the cables

The following table shows the thermal stresses acceptable by the cables depending on their insulation, their composition (Cu or Al) and their cross section. Cross-section values are expressed in mm² and stresses in A²s.

S (mm ²)		1.5	2.5	4	6	10
PVC	Cu	2.97 x 10 ⁴	8.26 x 10 ⁴	2.12 x 10 ⁵	4.76 x 10 ⁵	1.32 x 10 ⁶
	Al					5.41 x 10 ⁵
PRC	Cu	4.10 x 10 ⁴	1.39 x 10 ⁵	2.92 x 10 ⁵	6.56 x 10 ⁵	1.82 x 10 ⁶
	Al					7.52 x 10 ⁵
S (mm ²)		16	25	35	50	
PVC	Cu	3.4 x 10 ⁶	8.26 x 10 ⁶	1.62 x 10 ⁷	3.21 x 10 ⁷	
	Al	1.39 x 10 ⁶	3.38 x 10 ⁶	6.64 x 10 ⁶	1.35 x 10 ⁷	
PRC	Cu	4.69 x 10 ⁶	1.39 x 10 ⁷	2.23 x 10 ⁷	4.56 x 10 ⁷	
	Al	1.93 x 10 ⁶	4.70 x 10 ⁶	9.23 x 10 ⁶	1.88 x 10 ⁷	

Example

Is a Cu/PVC cable of cross section 10 mm² protected by a NG125L device?

The above table shows that the acceptable stress is 1.32 x 10⁶ A²s. Any short-circuit current at the point where a NG125L device (I_{cu} = 25 kA) is installed will be limited, with a thermal stress of less than 2.2 x 10⁵ A²s. (Curve on page <?>).

The cable is therefore always protected up to the breaking capacity of the circuit breaker.

Short-circuit current limiting (cont.)

Limitation curves for network

Ue: 380-415 V AC (Ph/N 220-240 V AC)

DPN (MCB and RCBO)

1P+N / 3P / 3P+N

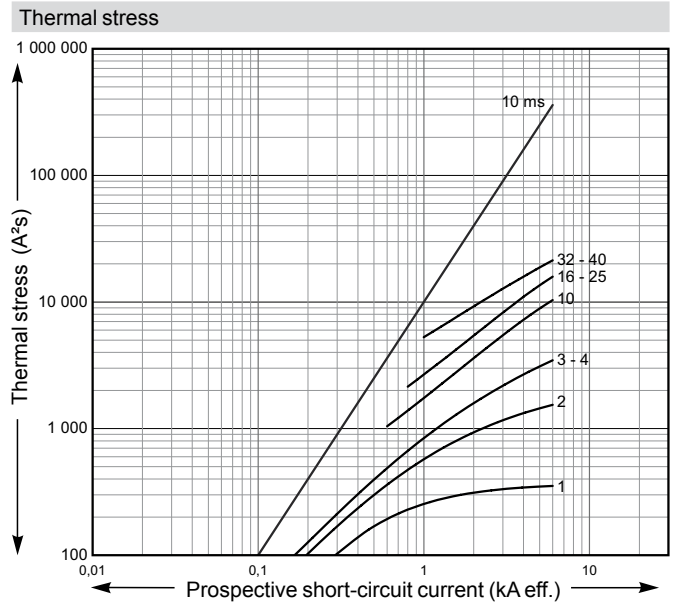
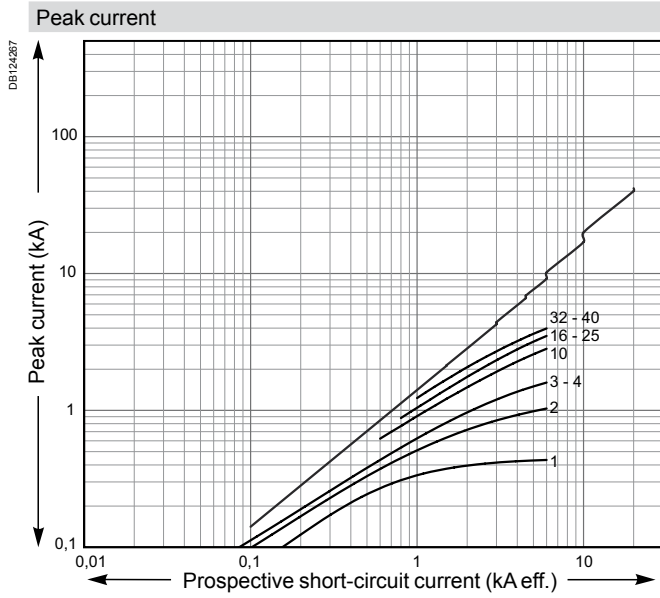

DPN N (MCB and RCBO)

1P+N / 3P / 3P+N

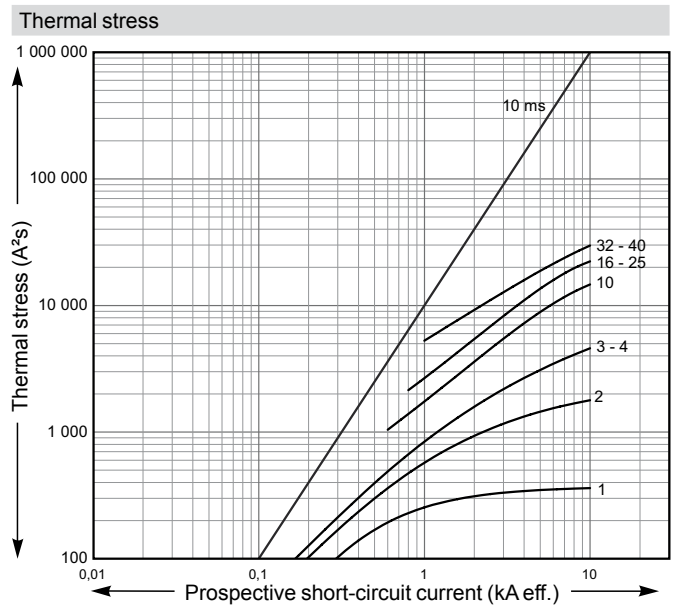
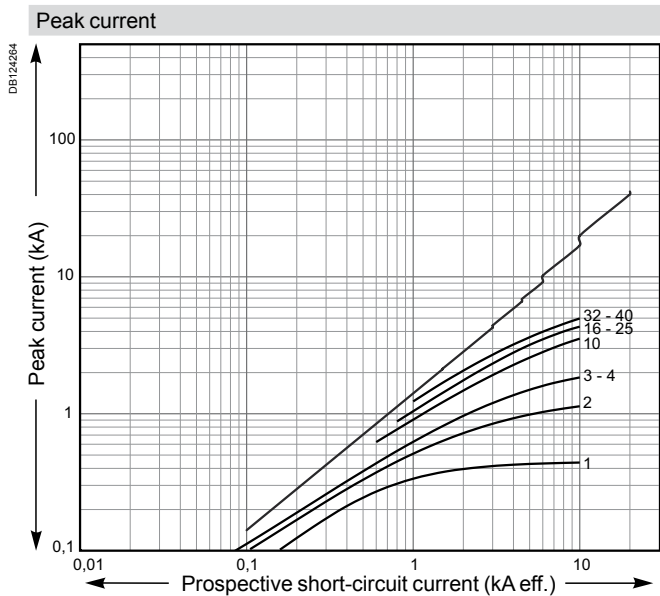

Short-circuit current limiting (cont.)

Limitation curves for network

U_e: 380-415 V AC (Ph/N 220-240 V AC)

iC60N

1P / 1P+N / 2P / 3P / 4P

Peak current

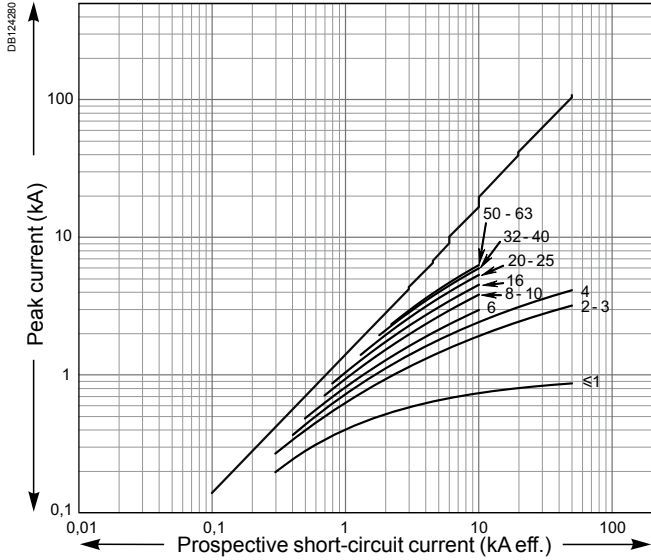

Thermal stress

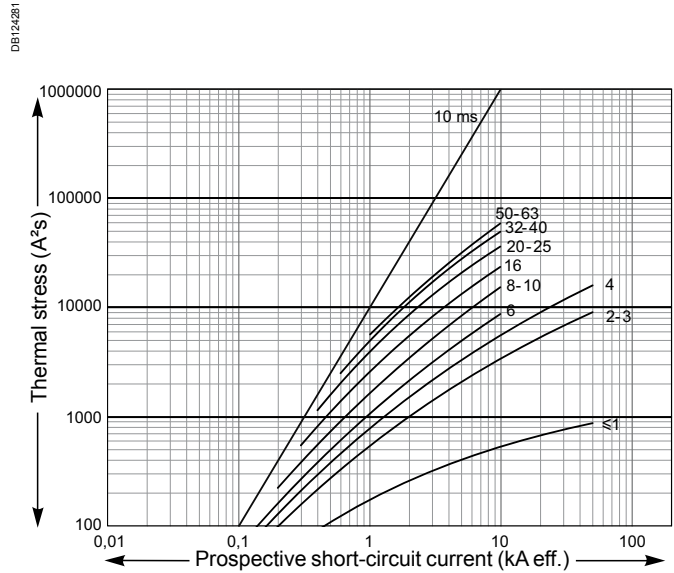

iC60H

1P / 1P+N / 2P / 3P / 4P

Peak current

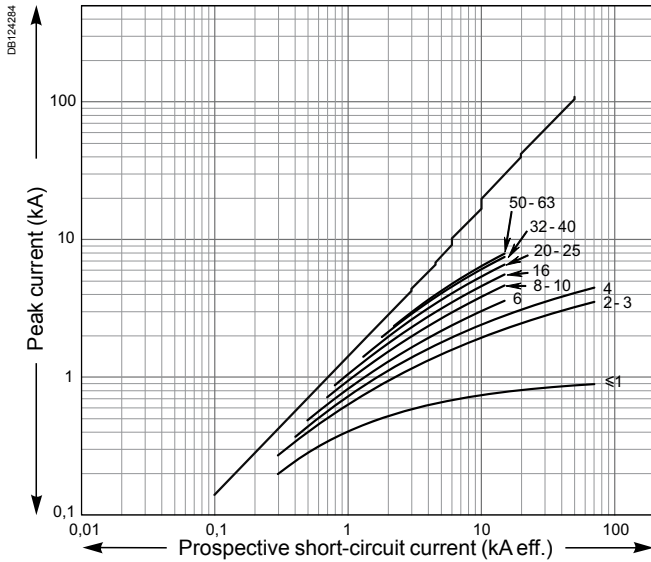

Thermal stress

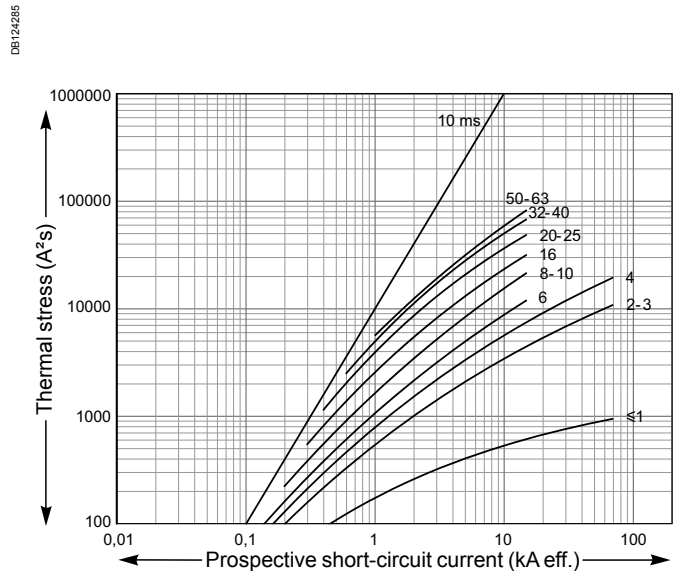

Short-circuit current limiting (cont.)

Limitation curves for network

U_e: 380-415 V AC (Ph/N 220-240 V AC)

iC60L

1P / 2P / 3P / 4P

Peak current

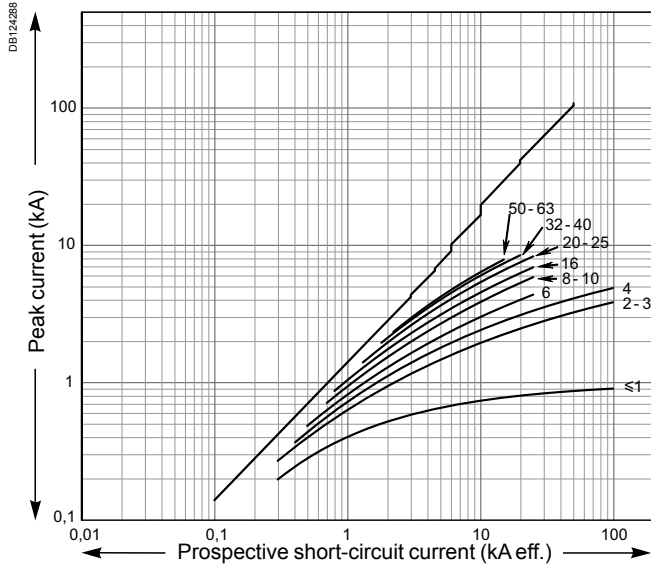

Thermal stress

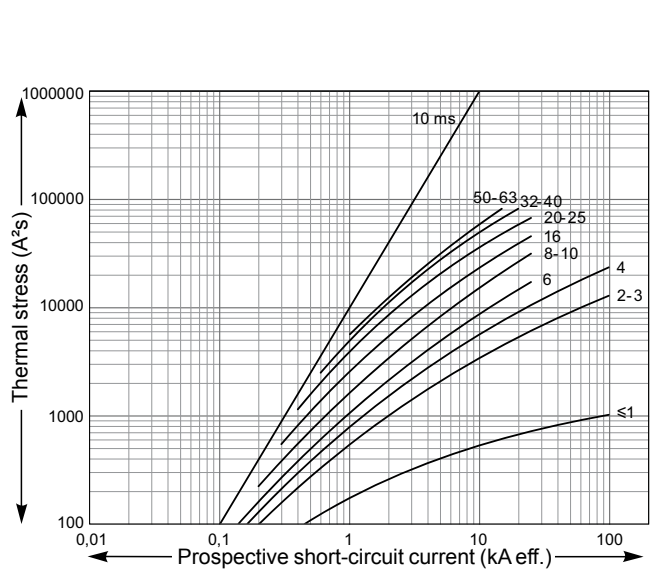

Short-circuit current limiting (cont.)

Limitation curves for network

U_e: 380-415 V AC (Ph/N 220-240 V AC)

C60a

1P / 2P / 3P / 3P+N / 4P

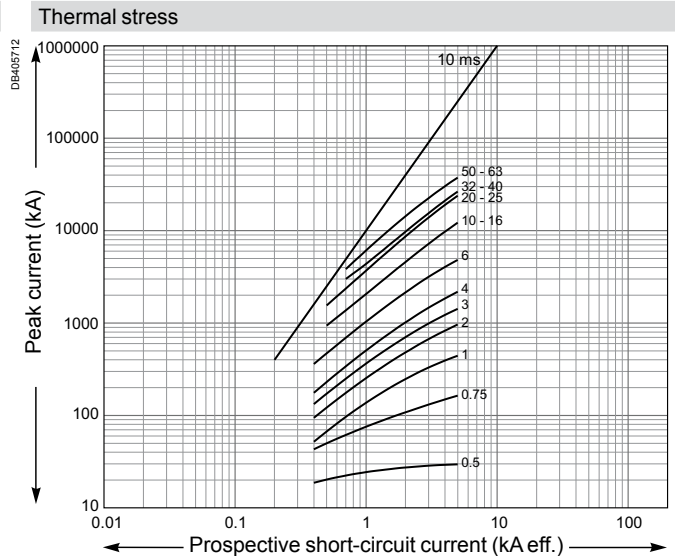
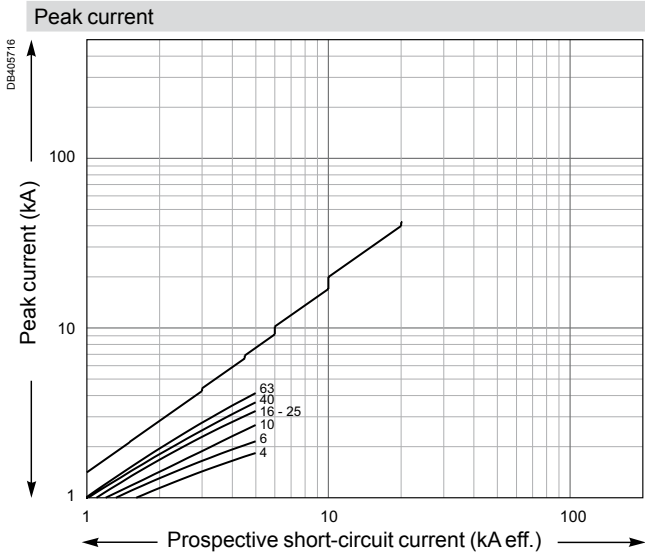

C60N

1P / 1P+N / 2P / 3P / 3P+N / 4P

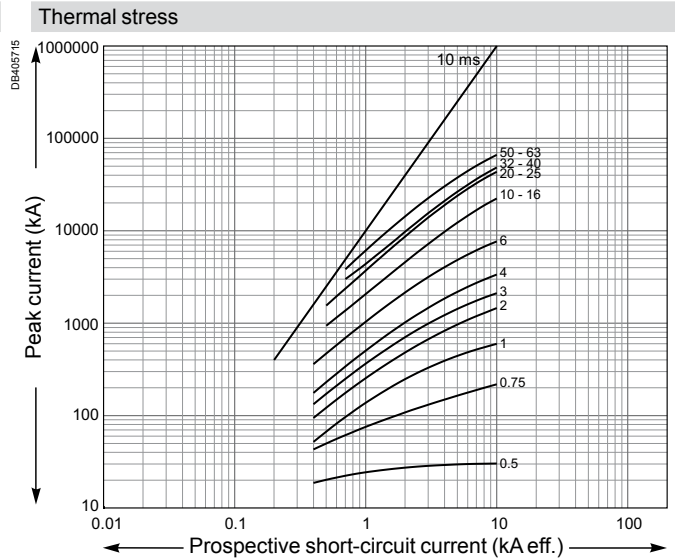
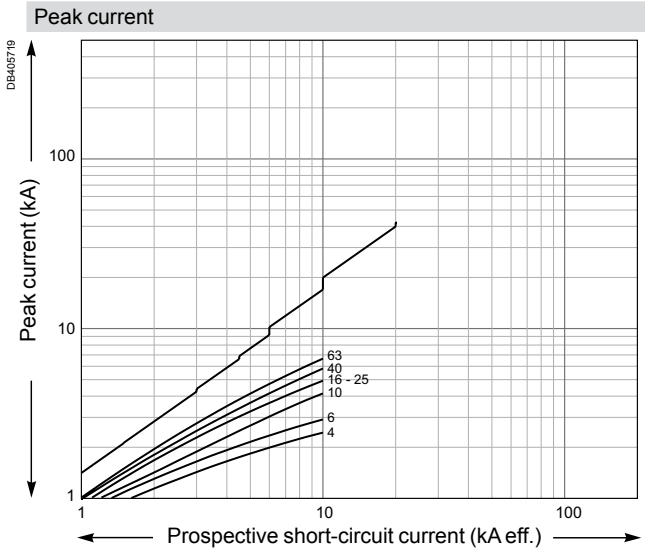

Short-circuit current limiting (cont.)

Limitation curves for network

U_e: 380-415 V AC (Ph/N 220-240 V AC)

C60H

1P / 1P+N / 2P / 3P / 3P+N / 4P

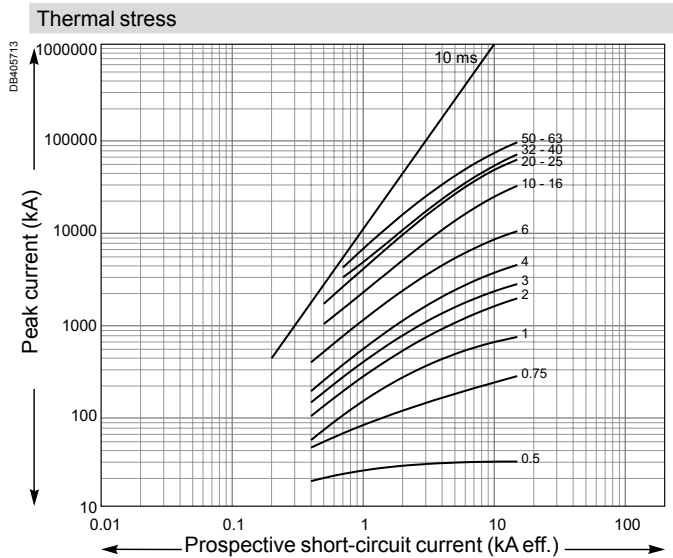
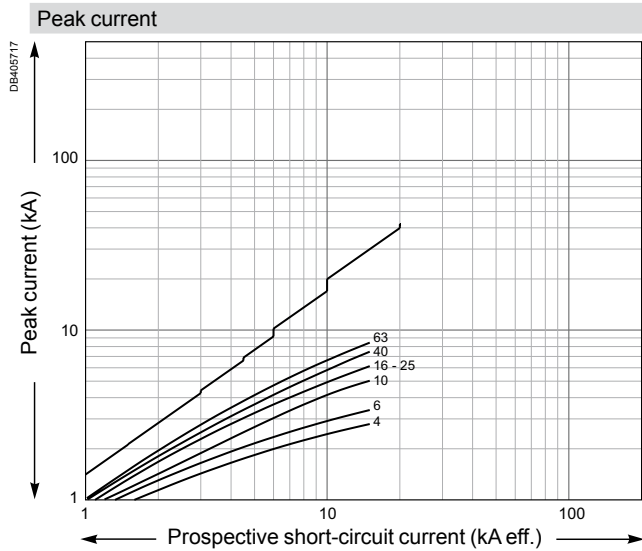

C60L

1P / 2P / 3P / 4P

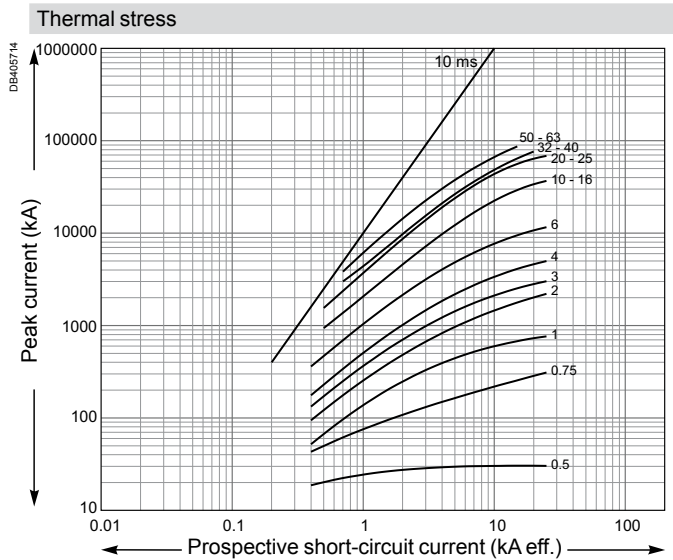
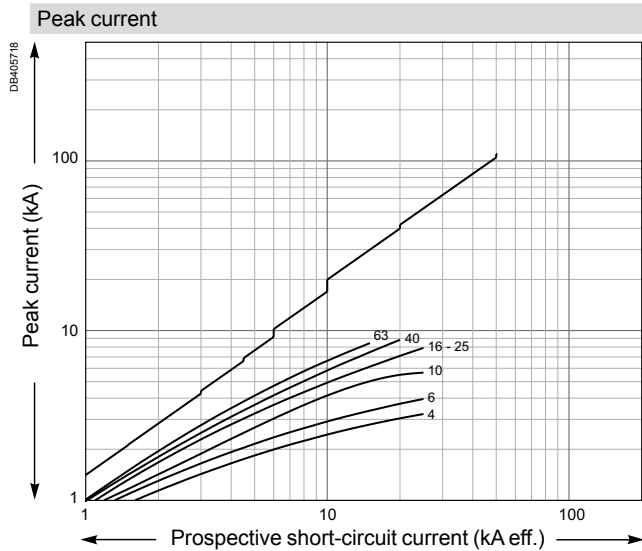

Limitation curves for network

U_e: 380-415 V AC (Ph/N 220-240 V AC)

C120N, H

1P / 2P / 3P / 4P

Peak current

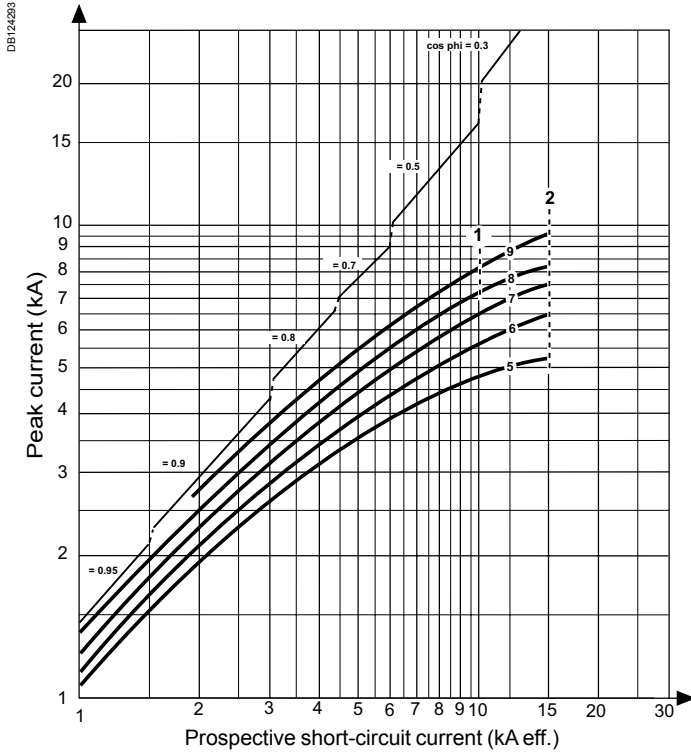

■ Circuit breaker type in accordance with the mark:

- 1: C120N
- 2: C120H
- 5: 10-16 A
- 6: 20-25 A
- 7: 32-40 A
- 8: 50-63 A
- 9: 80-125 A

Thermal stress

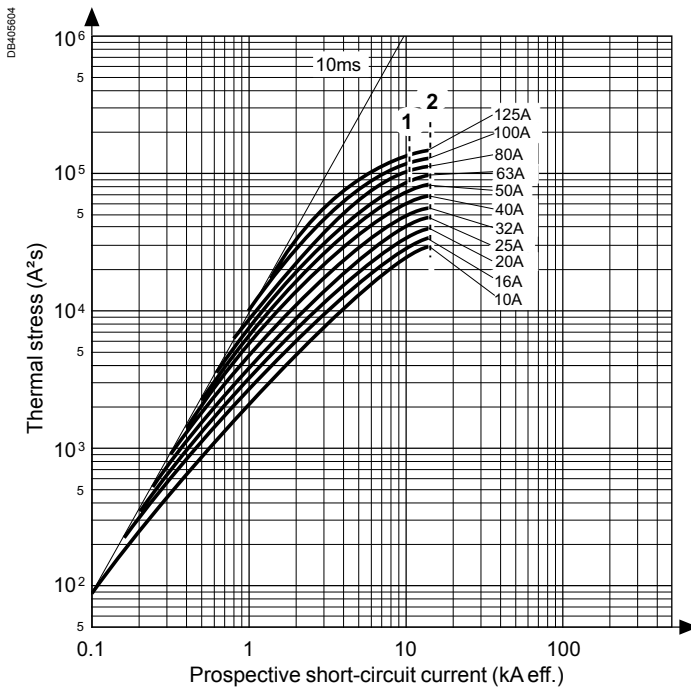

■ Circuit breaker type in accordance with the mark:

- 1: C120N
- 2: C120H

Limitation curves for network

U_e: 380-415 V AC (Ph/N 220-240 V AC)

NG125a, N, H, L

1P / 2P / 3P / 4P

Peak current

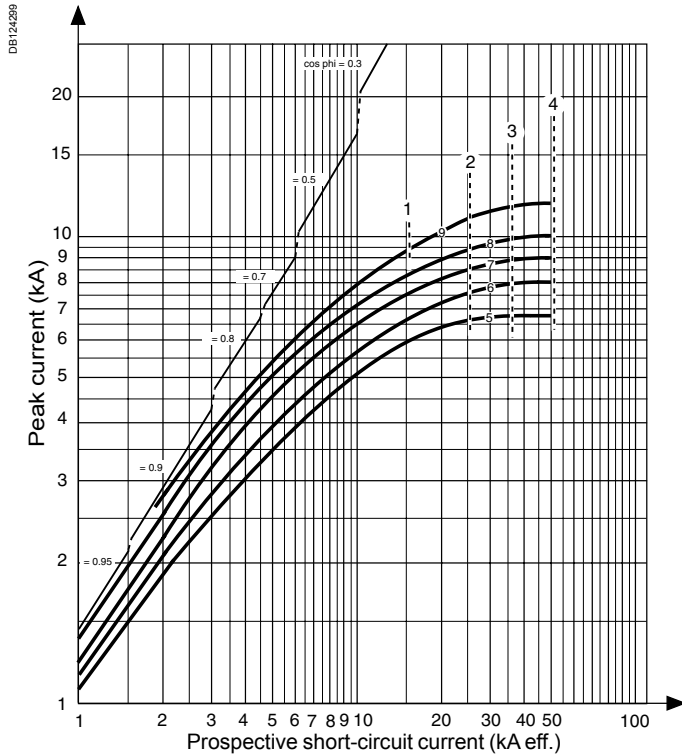

■ Circuit breaker type in accordance with the mark:

- 1: NG125a
- 2: NG125N
- 3: NG125H
- 4: NG125L
- 5: 10 -16 A
- 6: 20-25 A
- 7: 32-40 A
- 8: 50-63 A
- 9: 80-125 A

Thermal stress

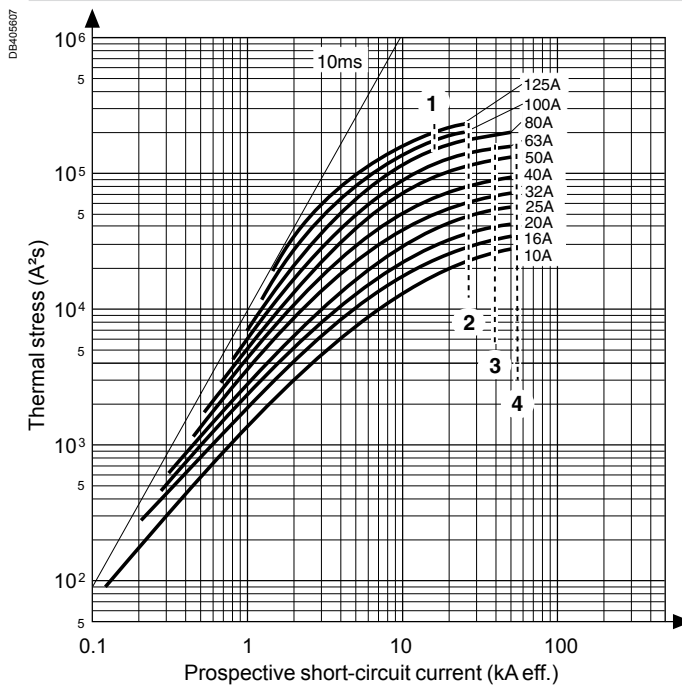

■ Circuit breaker type in accordance with the mark:

- 1: NG125a 80-100-125 A
- 2: NG125N
- 3: NG125H
- 4: NG125L

Short-circuit current limiting (cont.)

Limitation curves for network U_e: 440 V AC

C60N

2P / 3P / 4P

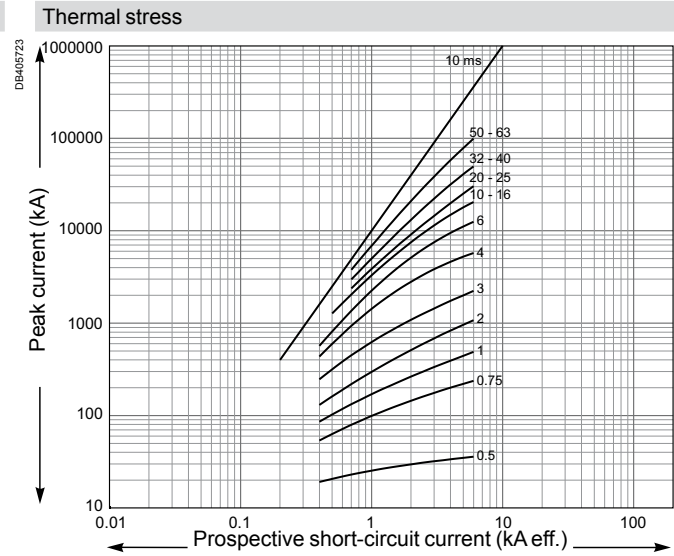
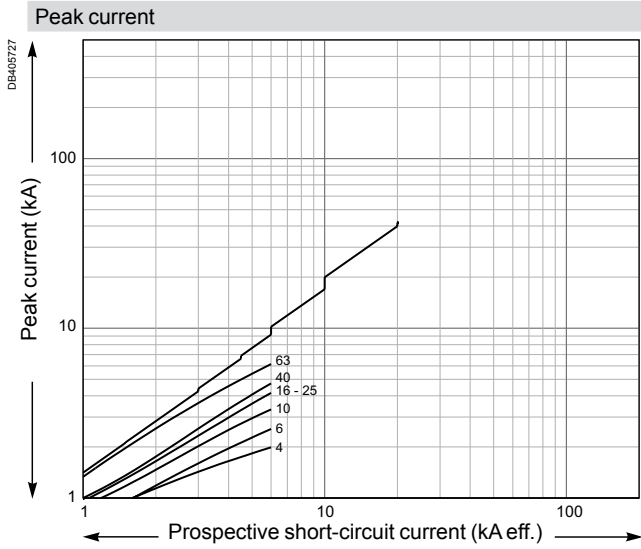

Short-circuit current limiting (cont.)

Limitation curves for network
 U_e: 440 V AC

C60H

2P / 3P / 4P

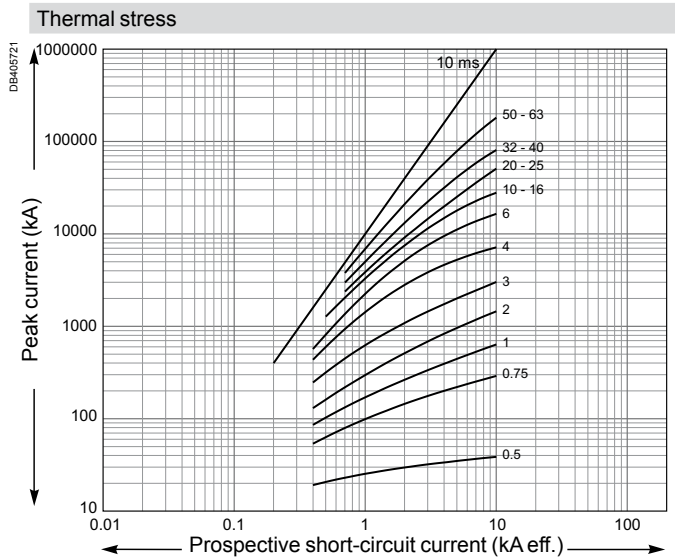
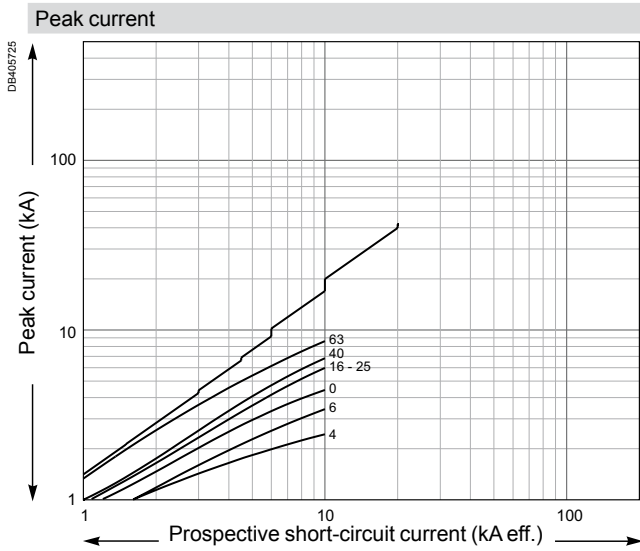

C60L

2P / 3P / 4P

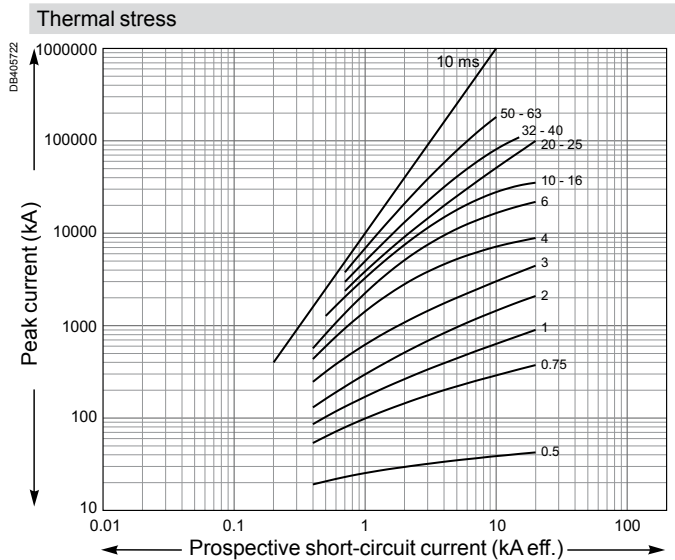
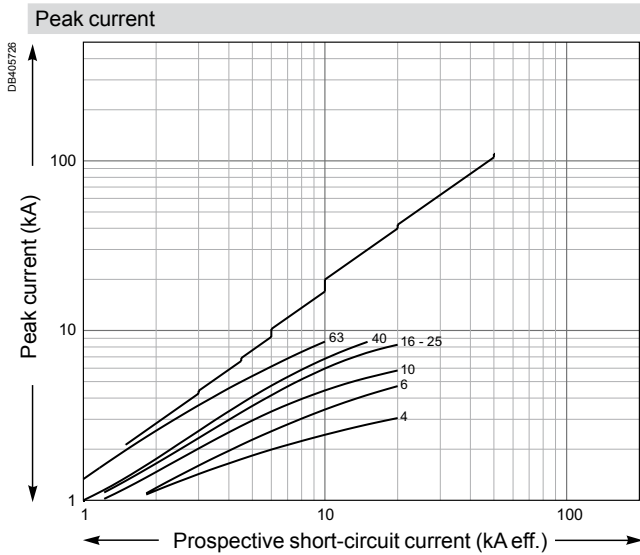

Limitation curves for network U_e: 440 V AC

C120N, H

2P / 3P / 4P

Peak current

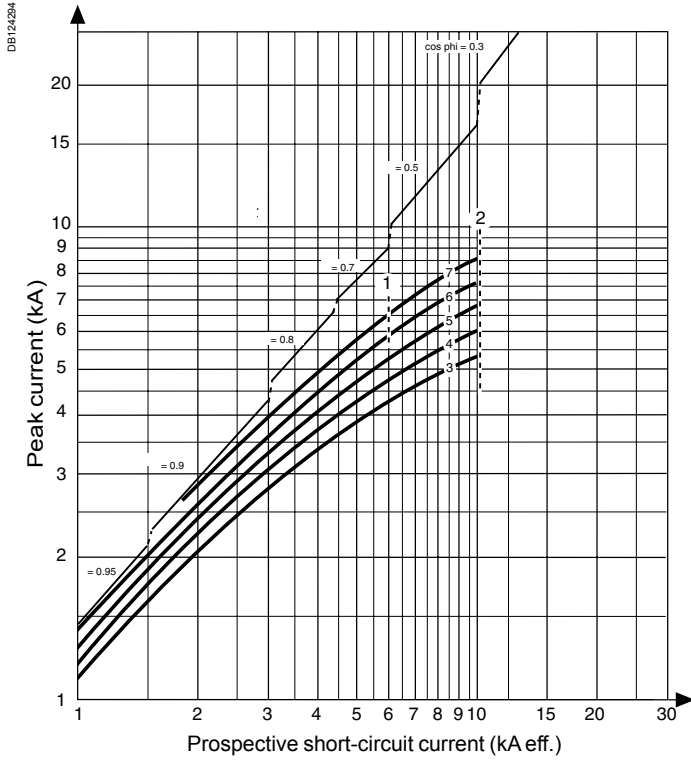

■ Circuit breaker type in accordance with the mark:

- 1: C120N
- 2: C120H
- 3: 0-16 A
- 4: 20-25 A
- 5: 32-40 A
- 6: 50-63 A
- 7: 80-125 A

Thermal stress

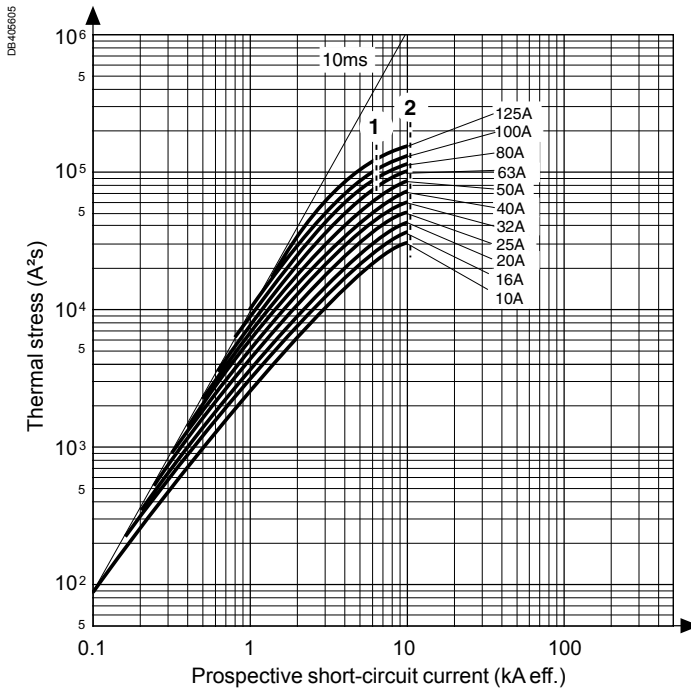

■ Circuit breaker type in accordance with the mark:

- 1: C120N
- 2: C120H

Limitation curves for network

U_e: 550 V AC

NG125a, N, H, L

2P / 3P / 4P

Peak current

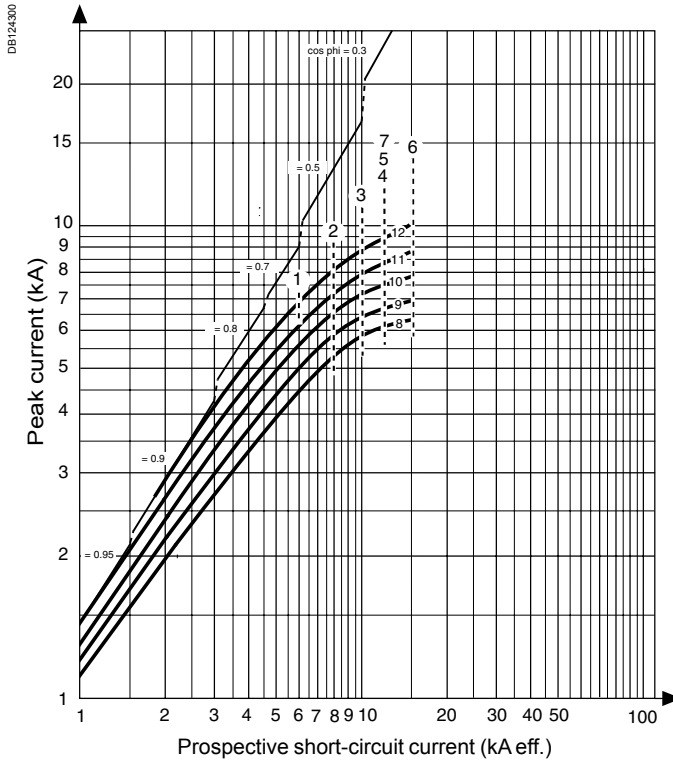

■ Circuit breaker type in accordance with the mark:

- 1: NG125a 3, 4P
- 2: NG125N 2, 3, 4P
- 3: NG125H 3, 4P
- 4-5: NG125H 2P/NG125L 3, 4P
- 6: NG125L 2P
- 7: NG125 LMA 2, 3, 4P
- 8: 10-16 A
- 9: 20-25 A
- 10: 32-40 A
- 11: 50-63 A
- 12: 80-125 A

Thermal stress

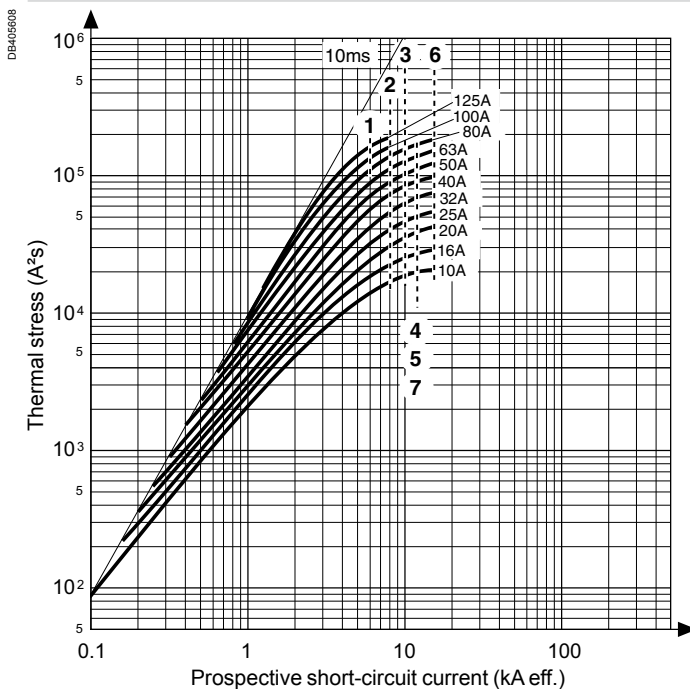

■ Circuit breaker type in accordance with the mark:

- 1: NG125a 3, 4P
- 2: NG125N 2, 3, 4P
- 3: NG125H 3, 4P
- 4-5: NG125H 2P/NG125L 3, 4P
- 6: NG125L 2P
- 7: NG125LMA 2, 3, 4P

Short-circuit current limiting (cont.)

Limitation curves for network

U_e: 220-240 V AC (Ph/N 110-130 V AC)

C60a

1P / 2P / 3P / 3P+N / 4P

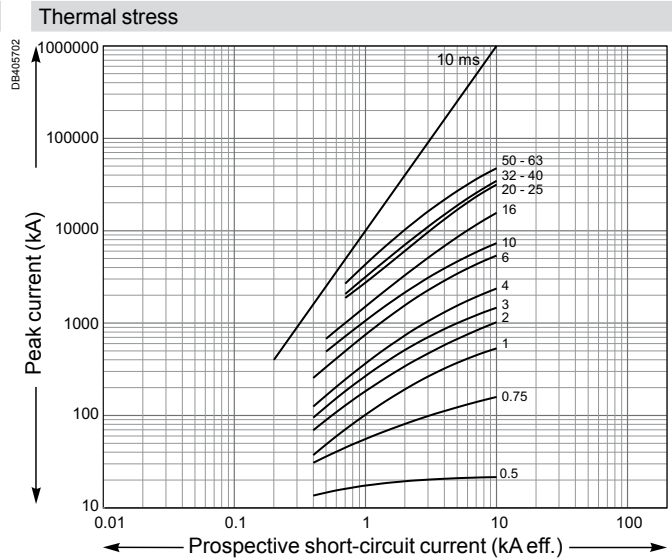
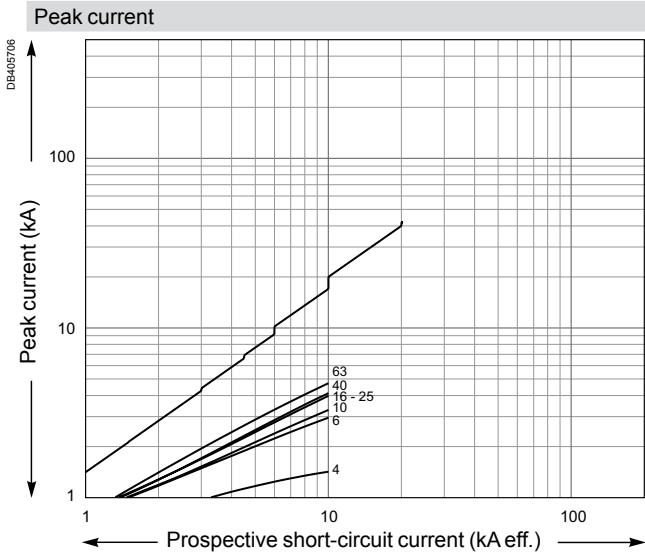

C60N

1P / 1P+N / 2P / 3P / 3P+N / 4P

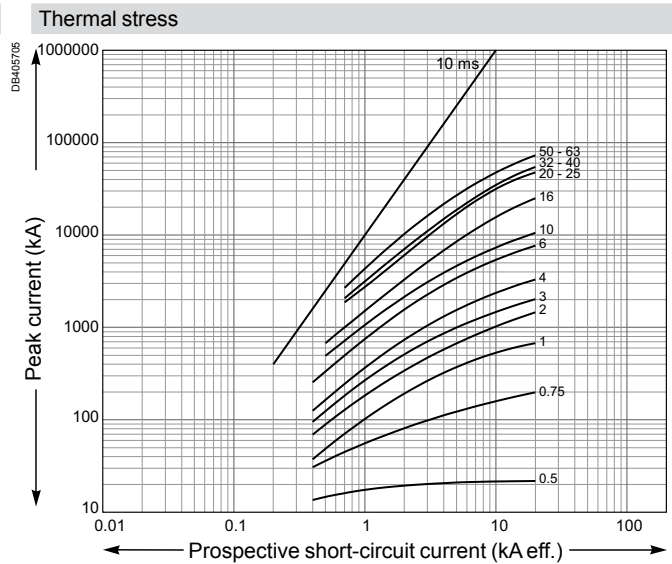
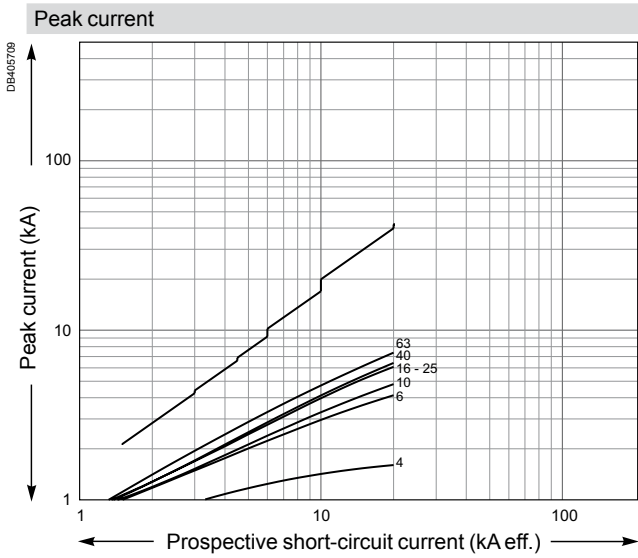

Short-circuit current limiting (cont.)

Limitation curves for network

U_e: 220-240 V AC (Ph/N 110-130 V AC)

C60H

1P / 1P+N / 2P / 3P / 3P+N / 4P

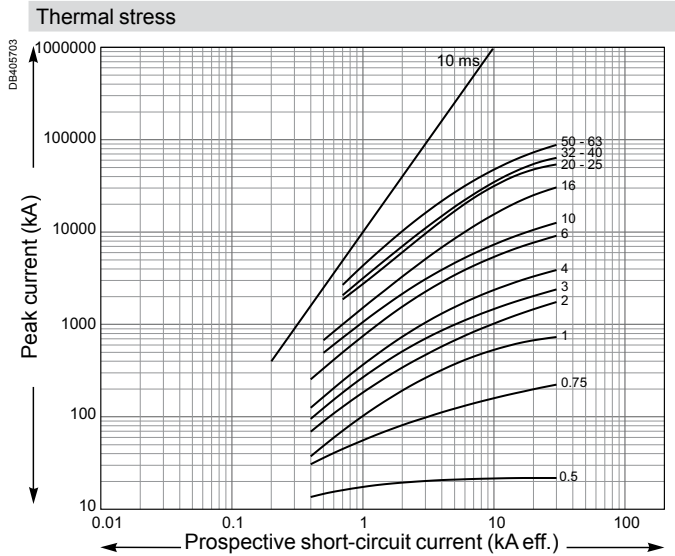
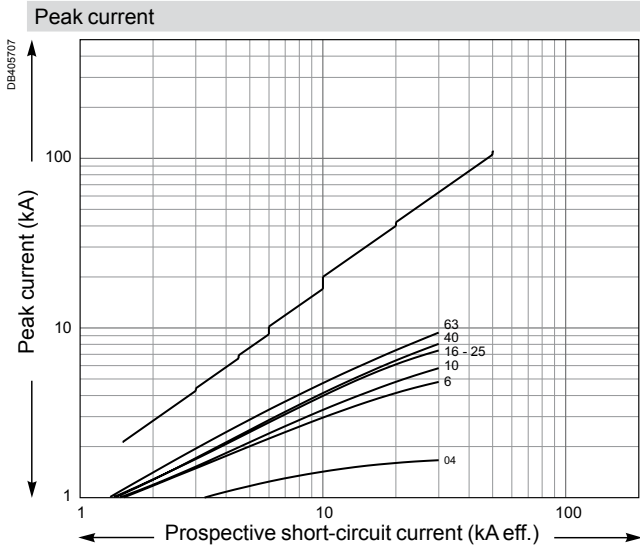

C60L

1P / 2P / 3P / 4P

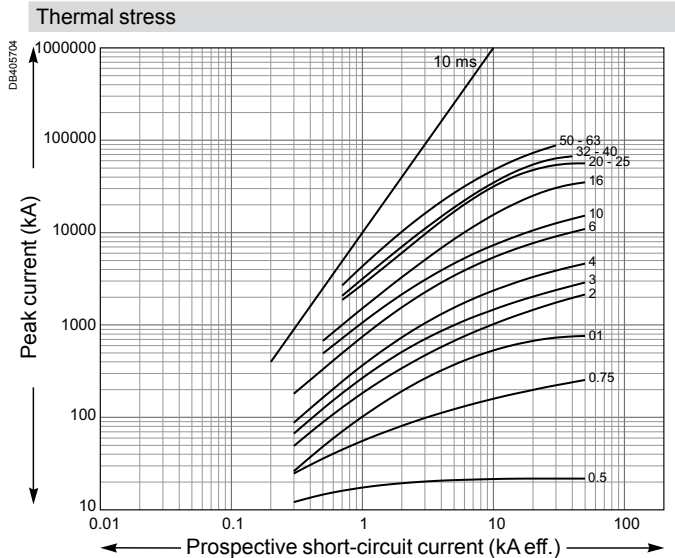
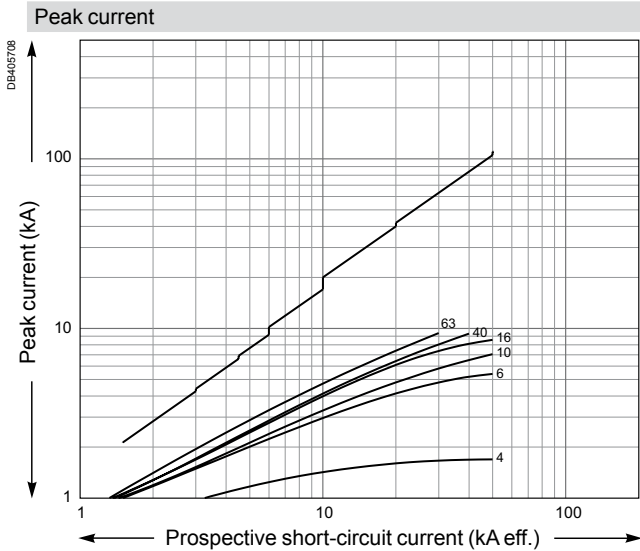

Short-circuit current limiting (cont.)

Limitation curves for network

U_e: 220-240 V AC (Ph/N 110-130 V AC)

C120N, H

1P / 2P / 3P / 4P

Peak current

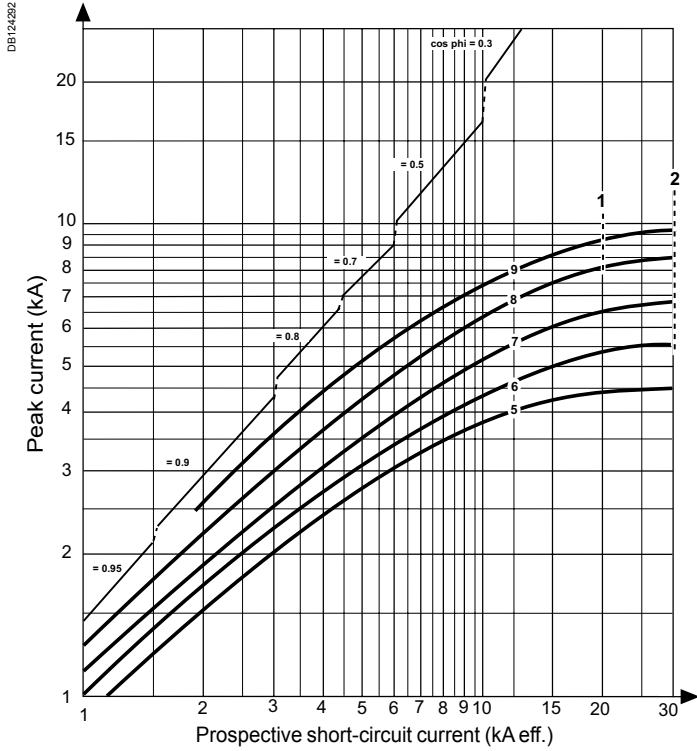

■ Circuit breaker type in accordance with the mark:

- 1: C120N
- 2: C120H
- 5: 10-16 A
- 6: 20-25 A
- 7: 32-40 A
- 8: 50-63 A
- 9: 80-125 A

Thermal stress

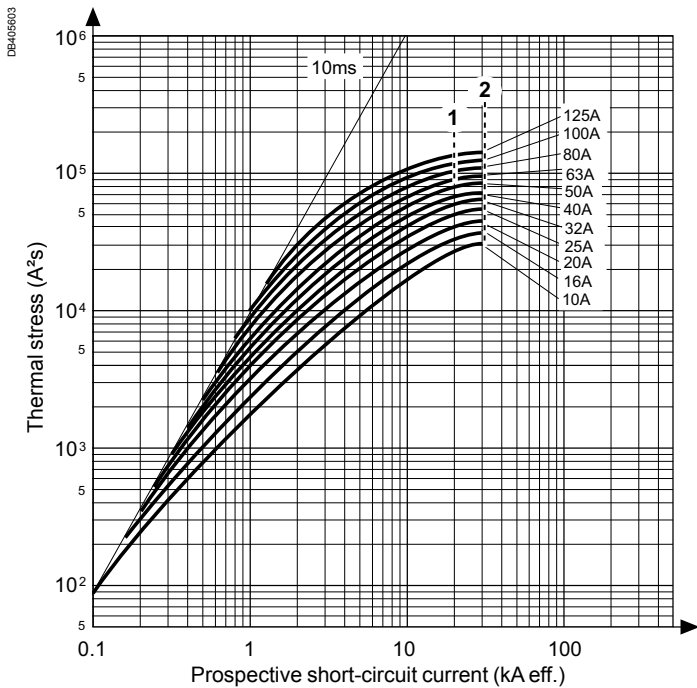

■ Circuit breaker type in accordance with the mark:

- 1: C120N
- 2: C120H

Limitation curves for network

U_e: 220-240 V AC (Ph/N 110-130 V AC)

NG125a, N, H, L

1P / 2P / 3P / 4P

Peak current

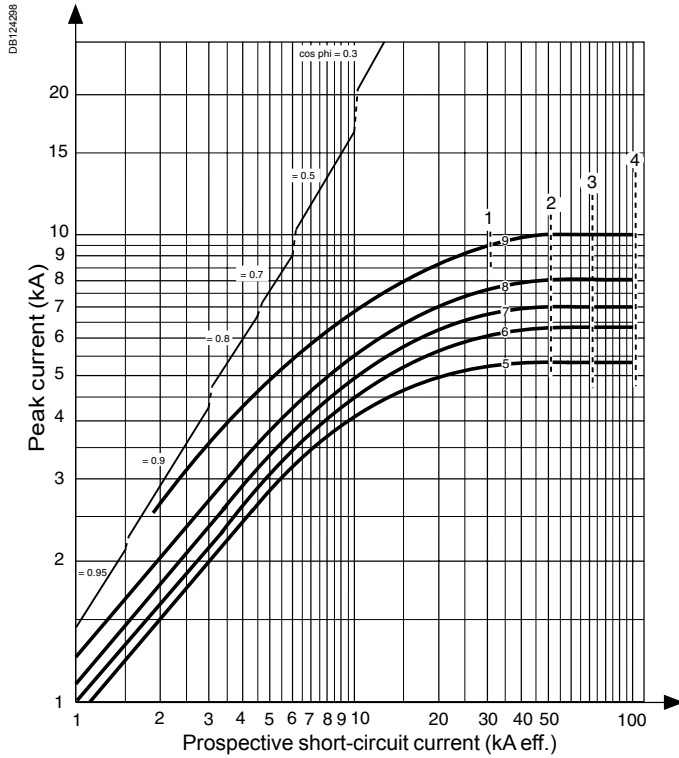

■ Circuit breaker type in accordance with the mark:

- 1: NG125a
- 2: NG125N
- 3: NG125H
- 4: NG125L
- 5: 10-16 A
- 6: 20-25 A
- 7: 32-40 A
- 8: 50-63 A
- 9: 80-125 A

Thermal stress

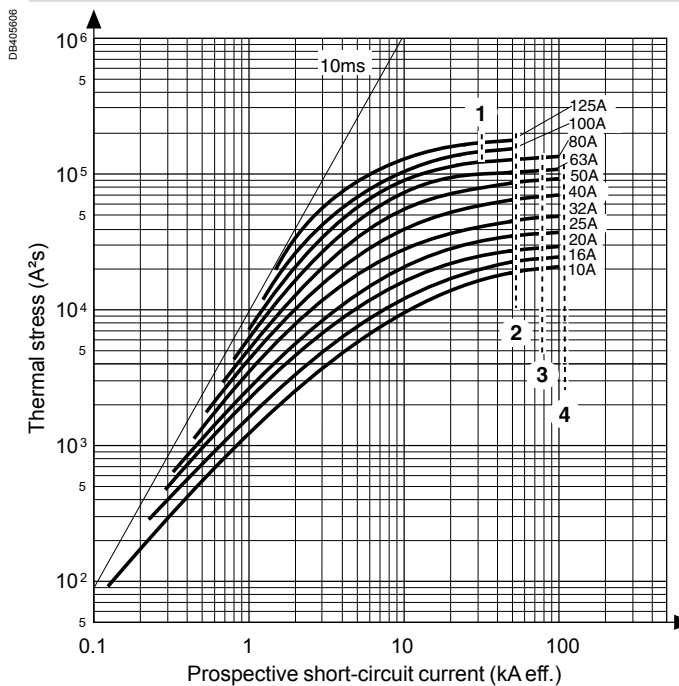

■ Circuit breaker type in accordance with the mark:

- 1: NG125a 80-100-125 A
- 2: NG125N
- 3: NG125H
- 4: NG125L

Short-circuit current limiting (cont.)

Limitation curves for direct current network

C60H-DC curve C

1P (220 V) - 2P (440 V)

Peak current

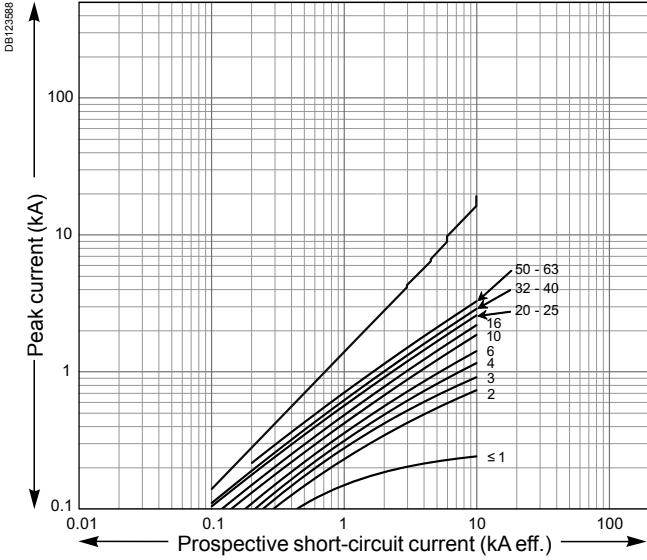

Thermal stress

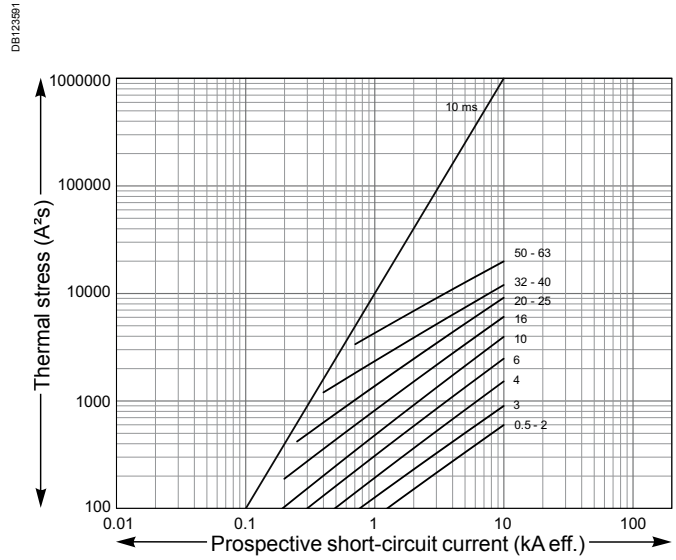

C60H-DC curve C

1P (250 V DC) - 2P (500 V DC)

Peak current

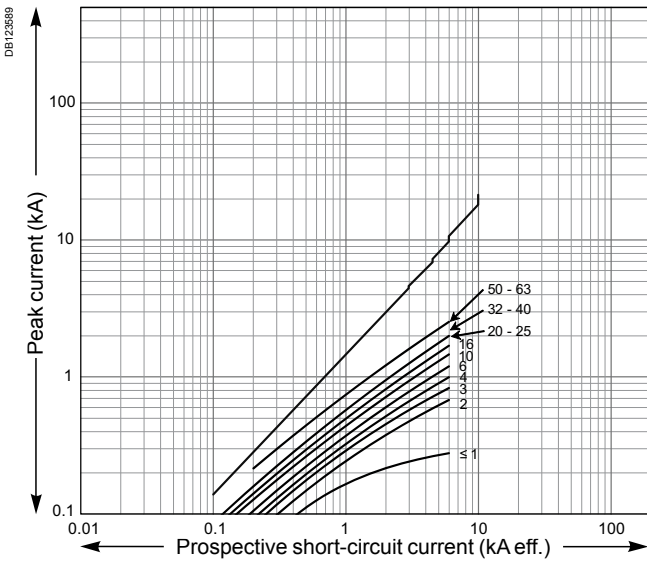

Thermal stress

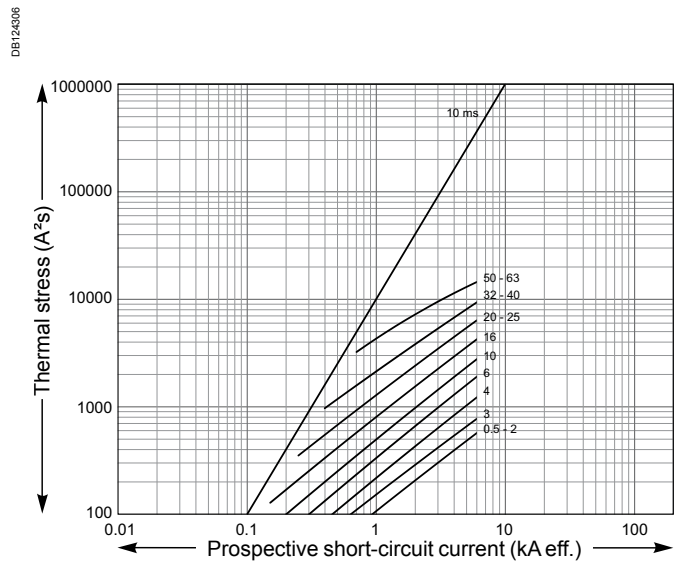

Circuit breakers for direct current applications

24 V - 48 V direct current applications

Typical applications

Direct current has been used for a long time and in many fields. It offers major advantages, in particular immunity to electrical interference. Moreover, direct-current installations are now simpler, because they benefit from the development of power supplies with electronic converters and batteries.

- Communication or measurement network:
 - 48 V DC switched telephone network,
 - 4-20 mA current loop.
- Electrical supply for industrial PLCs:
 - PLCs and peripheral devices (24 or 48 V DC).
- Auxiliary uninterruptible direct current power supply:
 - relays or electronic protection units for MV cubicles,
 - switchgear opening / closing trip units,
 - LV control and monitoring relays,
 - indicator lights,
 - circuit-breaker or on/off switch motor drives,
 - power contactor coils,
 - control/monitoring and supervision devices with communication that can be powered via a separate uninterruptible power supply.
- 24 to 48 V DC wind application:
 - isolated homes,
 - cottages, bungalows, mountain refuges,
 - pumps, street lighting,
 - measuring instruments, data acquisition,
 - telecommunication relays,
 - industrial applications.

Types of direct current networks

According to the types of DC networks illustrated below, we can identify the risks to the installation and define the best means of protection.

Earthed		Isolated from earth	
I: Earthed (or grounded) polarity (in this case negative)		II: Earthed mid-point	III: Isolated polarities
1 pole (1P isolation)	2 poles (2P isolation)	2 poles	2 poles
	2 poles (1P isolation 1P+N)		
Worst-case faults			
Fault A and fault B (if only one polarity is protected)		Fault B	Double fault A and D or C and E

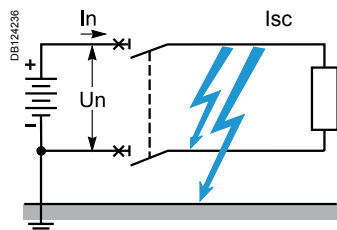

For further information on the types of networks and the faults that characterise them, refer to the direct current circuit breaker (LV) selection guide, 220E2100.indd.

For all these configurations, we propose a single protection solution that depends only on the requirement for the nominal current I_n and the short-circuit current I_{sc} at the installation point concerned.

The second important point in our solution is the fact that the protection is implemented by non-polarised circuit breakers that can operate efficiently, whatever the direction of the direct current.

Circuit breakers for direct current applications (cont.)

24 V - 48 V direct current applications

24 - 48 V direct current protection solution

The performance levels shown in the tables below correspond to the most critical faults according to the network configuration.

- Breaking on one pole.
- Fault between polarity and earth (Fault A).

Standard solution depending on the network and the requirements of the installation (In / Isc)

In addition to the parameters shown on the following pages, the tables below illustrate our range of circuit breakers according to the nominal current of the load and short-circuit current at the point of installation.

- Circuit breaker rating.
- Breaking capacity of the circuit breaker.

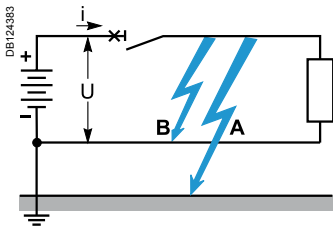

1 pole isolation solution (1P)

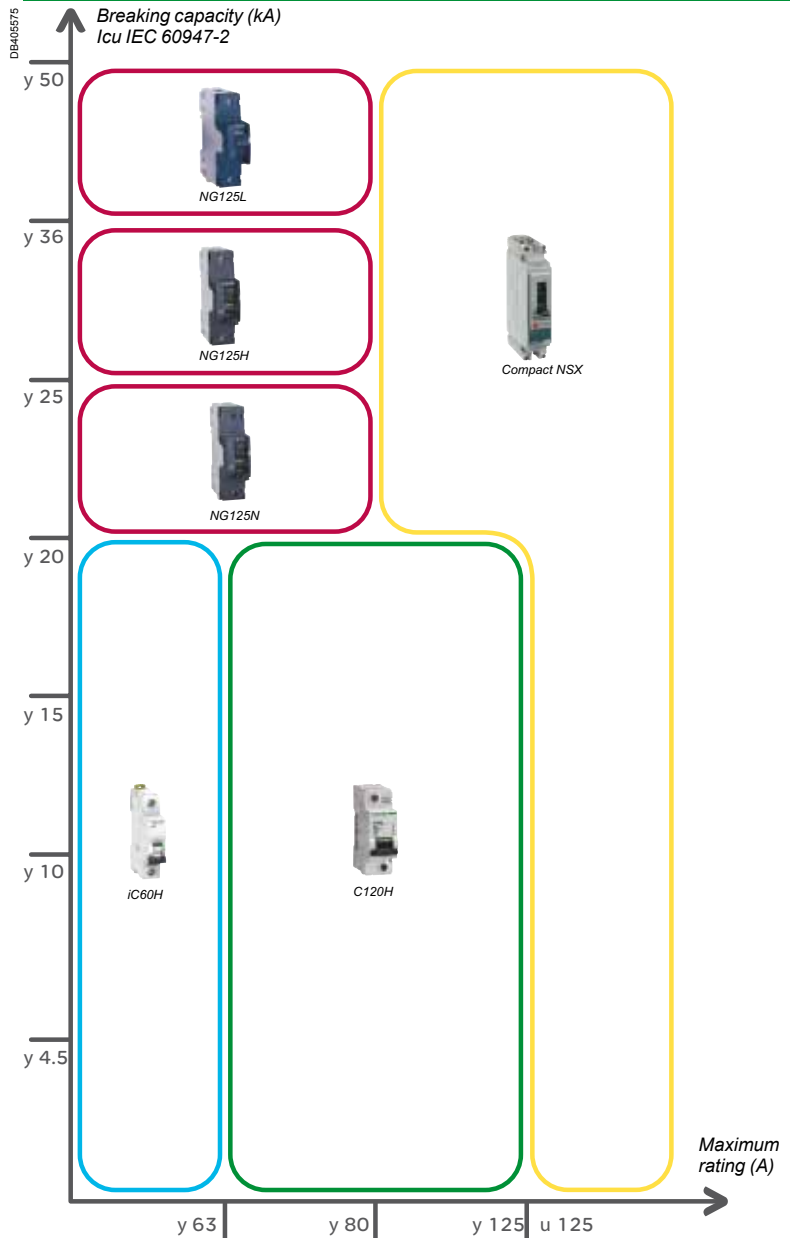

Circuit breakers for direct current applications (cont.)

24 V - 48 V direct current applications

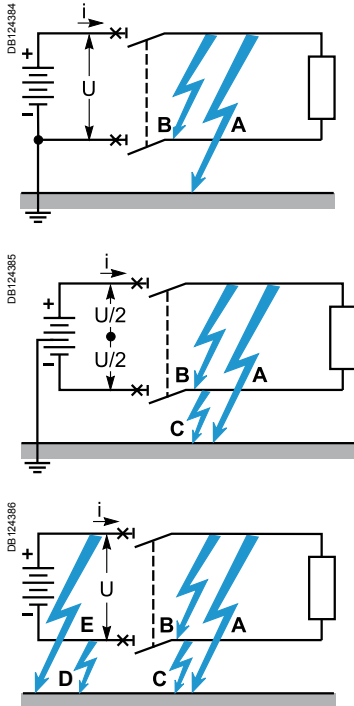

2 pôles isolation solution (2P)

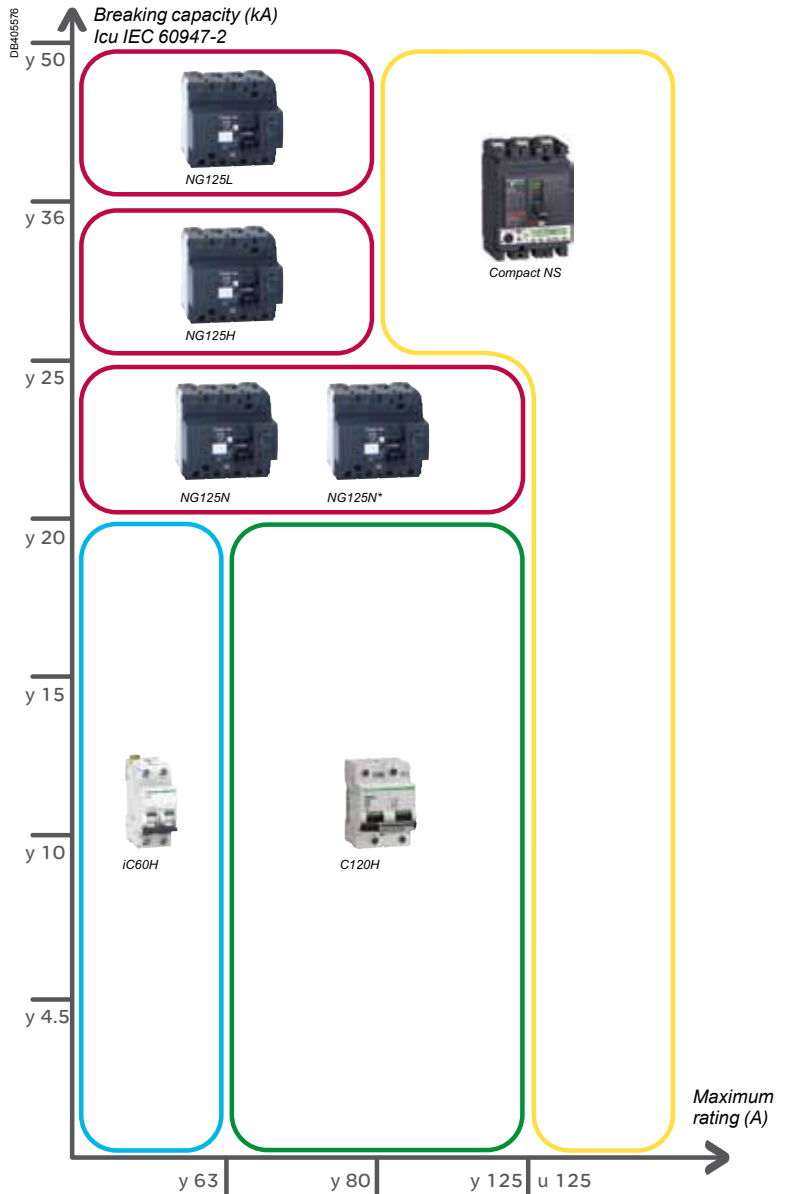

(*) 3P NG125N connected in a two-pole configuration to reach 125 A (1P/2P NG125 has a maximum rating of 80 A).

1 pole isolation solution (1P+N)

Specific use of the iDPN range in a network with one polarity earthed and both poles isolated: compact solution (1P+N in 18 mm).

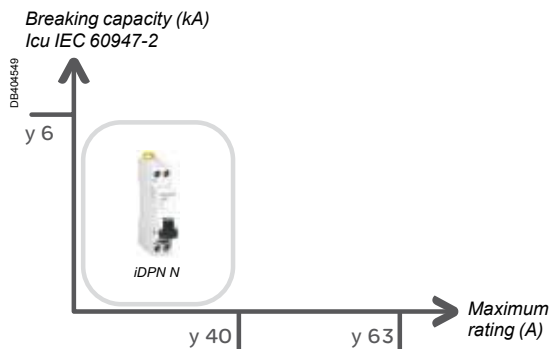
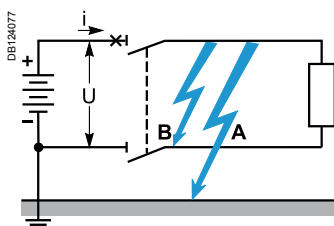

(*) iC60a breaking capacity Icu = 10 kA.

Circuit breakers for direct current applications (cont.)

24 V - 48 V direct current applications

Constraints related to "direct current" applications

In direct current, inductors and capacitors do not disturb the operation of the installation in steady state. Capacitors are charged and inductors no longer oppose changes in the current.

However, they create transient phenomena when the circuit opens or closes, during which time the current varies. Actual loads have both characteristics and generate oscillatory phenomena.

Type of load

Inductive load

An inductive load will tend to lengthen the current interrupt or establishment time, because the inductance L then opposes the change in the current ($L di/dt$). The transient phenomenon will mainly be characterised by a time constant imposed by the load and whose value corresponds approximately to the interrupt or closing time that the switchgear has to withstand. In addition, during the interrupt time, the switchgear must be able to withstand the additional energy stored in the inductor in steady state.

An inductive load therefore requires particular attention with respect to its time constant.

A low value (typically < 5 ms) facilitates interruption.

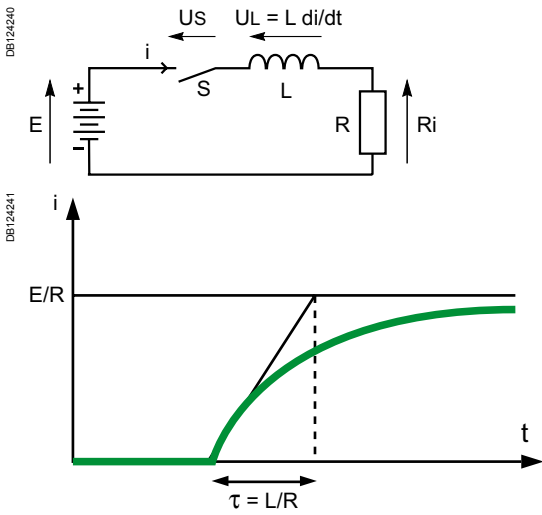

Inductive load

Capacitive load

During a closing operation, a capacitive load will cause an inrush current due to the load on the capacitor, virtually under short-circuit condition at the beginning of the phenomenon.

On opening, it will tend to discharge. The time constant is generally very low (< 1 ms) and its effect is secondary with respect to the inrush current. A capacitive load will require particular attention to the inrush or discharge current surges.

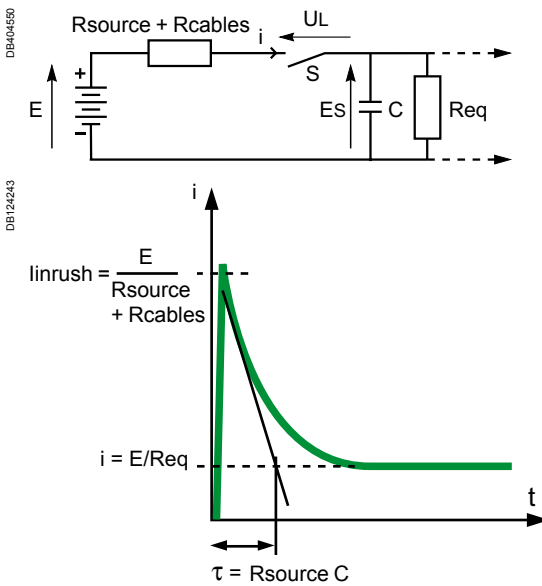

Capacitive load

Circuit breakers for direct current applications (cont.)

24 V - 48 V direct current applications

Time constant L/R

When a short-circuit occurs across the terminals of a direct current circuit, the current increases from the operating current ($< I_n$) to the short-circuit current I_{sc} during a time depending on the resistance R and the inductance L of the short-circuited loop.

The equation that governs the current in this loop is: $U = Ri + Ldi/dt$.

A short-circuit current is established (neglecting I_n with respect to I_{sc}) by the equation:

$$i = I_{sc} (1 - \exp(-t/\tau)),$$

where $\tau = L/R$ is the time constant used to establish the short-circuit.

In practice, after a time $t = 3\tau$ the short-circuit is considered to be established, because the value of $\exp(-3) = 0.05$ is negligible compared to 1.

The lower the corresponding time constant (e.g. battery circuit), the faster a short-circuit is established.

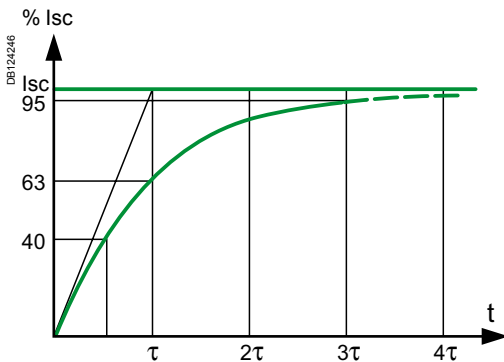
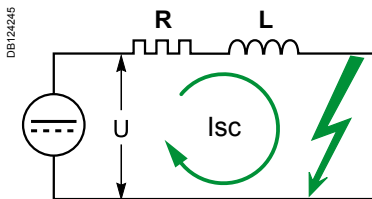

L/R	Description	DC applications
2 ms	Very fast short-circuit	<ul style="list-style-type: none"> ■ Photovoltaic applications
5 ms	Fast short-circuit established	<ul style="list-style-type: none"> ■ Resistive or slightly inductive circuits: <ul style="list-style-type: none"> <input type="checkbox"/> indicator light <input type="checkbox"/> trip units (MN, MX) <input type="checkbox"/> motor armatures <input type="checkbox"/> battery charger/uninterruptible power supply (UPS) ■ Capacitive circuits: electronic controller
15 ms	Standardised value used in standard IEC 60947-2	<ul style="list-style-type: none"> ■ Inductive circuits: <ul style="list-style-type: none"> <input type="checkbox"/> electromagnetic coil <input type="checkbox"/> contactor coil <input type="checkbox"/> motor inductor
30 ms	Slower short-circuit established	<ul style="list-style-type: none"> ■ Highly inductive circuits: <ul style="list-style-type: none"> <input type="checkbox"/> electromagnetic coil <input type="checkbox"/> contactor coil <input type="checkbox"/> motor inductor

In general, the system time constant is calculated under worst case conditions, across the terminals of the generator.

Circuit breakers for direct current applications (cont.)

24 V - 48 V direct current applications

Tripping curves

We can choose our solution according to the inrush currents generated by our loads, in the same way as for alternating current. In direct current, the same thermal tripping curves are obtained as in alternating current. The only difference is that the magnetic thresholds are offset by a coefficient $\sqrt{2}$ compared to the curves obtained in alternating current.

Characteristics of the various curves and their applications:

Curves	Magnetic thresholds		DC applications
	AC	DC	
Z	2.4 to 3.6 In	3.4 to 5 In	<ul style="list-style-type: none"> Resistive loads Loads with electronic circuits
B	3.2 to 4.8 In	4.5 to 6.8 In	<ul style="list-style-type: none"> Motor inductor: starting current 2 to 4 In Battery charger/Uninterruptible power supply (UPS)
C	6.4 to 9.6 In	9.05 to 13.6 In	<ul style="list-style-type: none"> Electronic controller
D et K	9.6 to 14.4 In	13.6 to 20.4 In	<ul style="list-style-type: none"> Electromagnetic coil: inrush overvoltage 10 to 20 Un LV relay Trip units (MN, MX) Indicator light PLCs (industrial programmable logic controllers)

The figures opposite are iC60 tripping curves showing DC magnetic thresholds and normative limits

Example

Protection of the 4 mm² cable supplying a load at In = 30 A with a 32 A rating and a tripping curve that allows the starting current for this load to be absorbed.

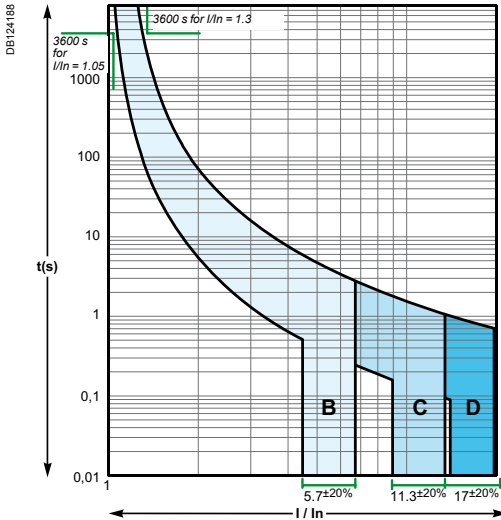

Curves B, C, D, ratings 6 A to 63 A

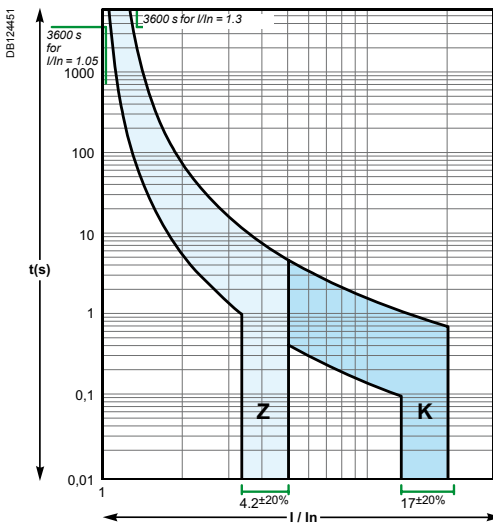

Curves Z, K, ratings 6 A to 63 A

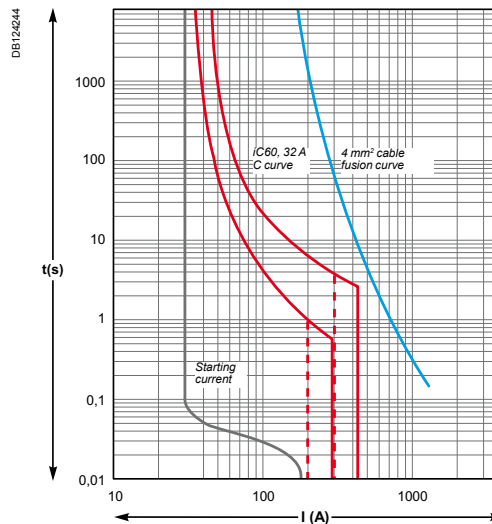

Curve C, rating 32 A (AC magnetic thresholds in dotted lines)

Circuit breakers for direct current applications (cont.)

24 V - 48 V direct current applications

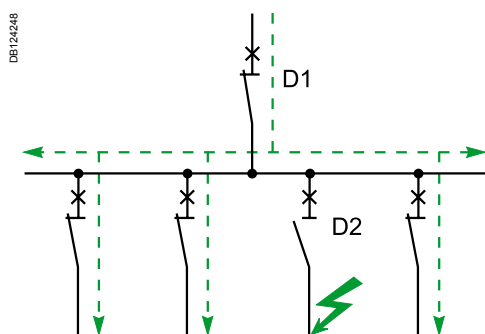
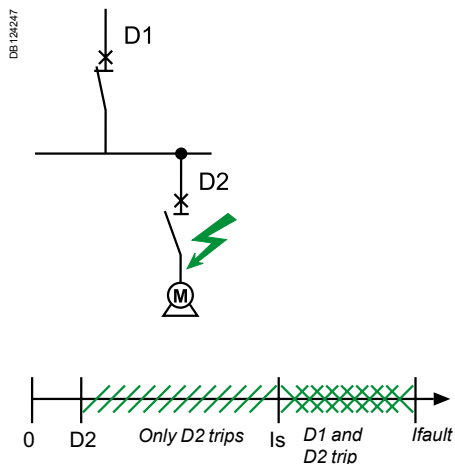

Continuity of service of the solutions

Discrimination of the direct current protection devices

Discrimination is a key element that must be taken into account right from the design stage of a low-voltage installation to allow continuity of service of the electrical power.

Discrimination involves coordination between two circuit breakers connected in series, so that in the event of a fault, only the circuit breaker positioned immediately upstream of the fault trips. A discrimination current I_s is defined as:

- $I_{\text{fault}} < I_s$: only D2 removes the fault, discrimination ensured,
- $I_{\text{fault}} > I_s$: both circuit breakers may trip, discrimination not ensured.

Discrimination may be partial or total, up to the breaking capacity of the downstream circuit breaker. To ensure total discrimination, the characteristics of the upstream device must be higher than those of the downstream one.

The same principles apply to designing both direct current and alternating current installations. Only the limit currents change when direct current is used.

Once again, we find the same concepts of discrimination:

- **total**: up to the breaking capacity of the downstream device. Our tests have been performed at up to 25 kA or 50 kA depending on the breaking capacity of the devices in question.
- **partial**: indication of the discrimination limit current I_s . Discrimination is ensured below this value; above this value, the upstream device participates in the breaking process,
- **none**: no discrimination ensured, the upstream and downstream circuit breakers will trip.

For further information about the discrimination concept for protection devices in general, refer to technical supplement 557E4300, "Discrimination of modular circuit breakers".

Total discrimination solutions

In the following tables, we offer you solutions that favour continuity of service (total discrimination between circuit breakers), for different short-circuit currents.

Total discrimination.

No discrimination.

Circuit breakers for direct current applications (cont.)

24 V - 48 V direct current applications

Total discrimination: 20 kA

		Upstream		Curve C		Time constant (L/R) = 15 ms				
In (A)		iC60H				C120H		NS		
		10 - 16	20 - 25	32	40	50 - 63	80	100	125	≥ 100
Downstream										
iC60H	≤ 3	T								
Curves B,C	4		T	T	T	T	T	T	T	T
	6				T	T	T	T	T	T
	10						T	T	T	T
	13						T	T	T	T
	16 to 25						T	T	T	T
	32							T	T	T
	40								T	T
	50 - 63								T	T

Total discrimination: 36 kA

		Upstream		Curve C		Time constant (L/R) = 15 ms				
In (A)		NG125H		NS						
		80		≥ 100						
Downstream										
NG125H	10	T		T						
Curves B,C	16 to 63			T						

Total discrimination: 50 kA

		Upstream		Curve C		Time constant (L/R) = 15 ms				
In (A)		NG125L		NS						
		80		≥ 100						
Downstream										
NG125L	10	T		T						
Curves B,C	16 to 63			T						

T Total discrimination.

No discrimination.

Circuit breakers for direct current applications

24 V - 48 V direct current applications

Coordination with loads

As seen above, the circuit-breaker characteristics chosen depend on the type of load downstream of the installation.

The rating depends on the size of the cables to be protected and the curves depend on the load inrush current.

Product selection according to the load inrush current

When certain "capacitive" loads are switched on, very high inrush currents appear during the first milliseconds of operation. The following graphs show the average DC non-tripping curves of our products for this time range (50 μ s to 10 ms).

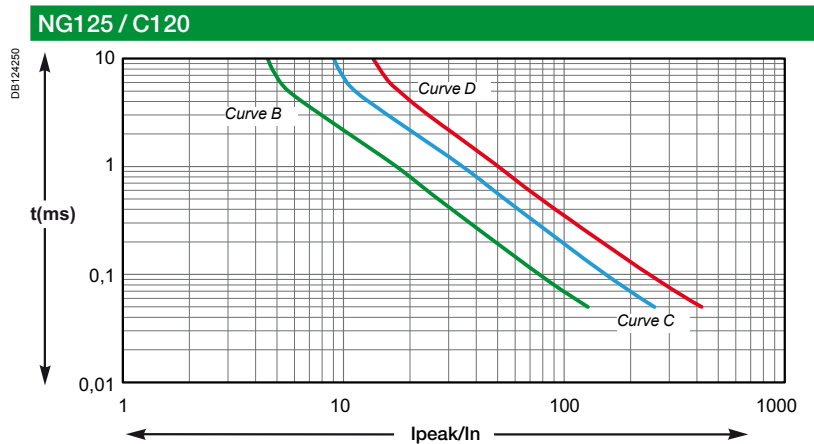
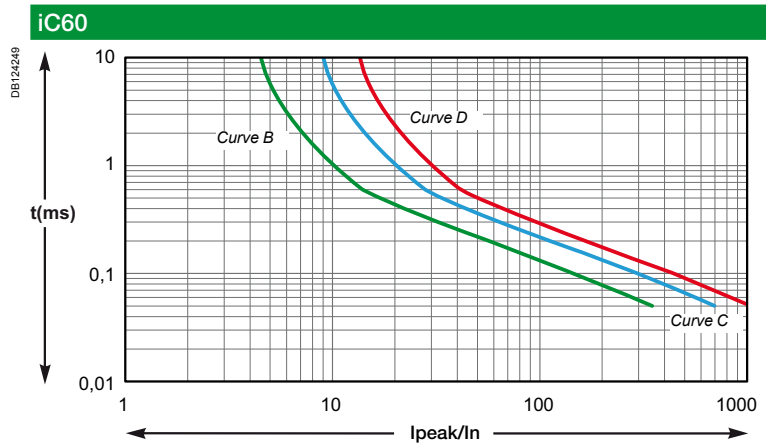

This information allows us to select the most appropriate product, according to the load specifications: curve and rating.

Example

When an iC60 is used with a load with current peaks in the order of 200 I_n during the first 0.1 millisecond, a curve C or D product must be installed.

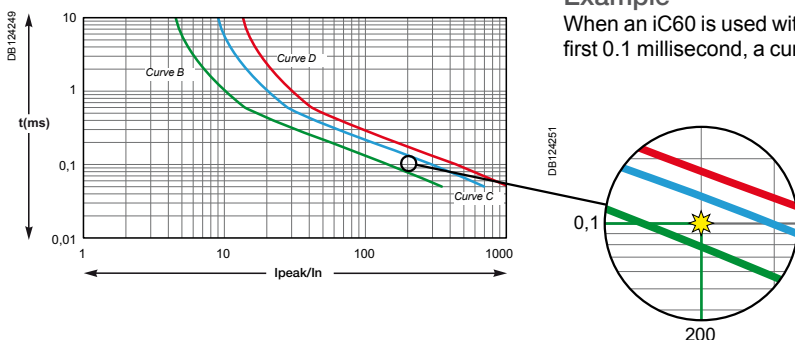

Circuit breakers for direct current applications

24 V - 48 V direct current applications

DE124238

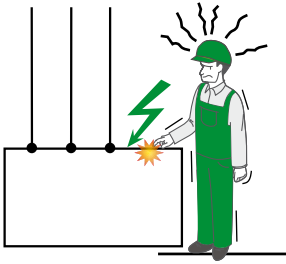

DE124239

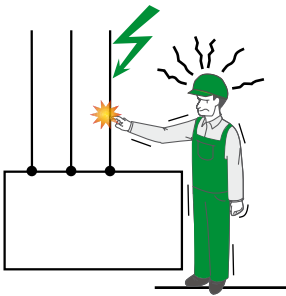

DE124237

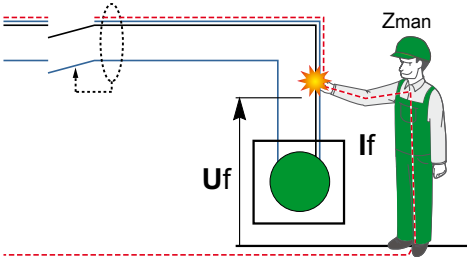

Standards: IEC 60479-2, NF C 15100, IEC 60755.

Personal protection

Personal protection (earth-leakage protection) is not mandatory for this voltage range (24-48 V DC).

In fact, according to the standards currently in force, the minimum ventricular fibrillation current I_f for human beings is in the order of 25 mA for alternating current (50 Hz), whereas for direct current, it is more than 50 mA.

The table below shows the data according to the standards and conditions:

Environment		Voltage specifications	
		AC	DC
Dry environment	$U_f = Z \times I_f$	50 V	100 V
Wet environment	$U_f = Z \times I_f$	25 V	50 V

With Z corresponding to the impedance of the human body in the different types of environment, I_f being the current passing through the body and U_f the minimum contact voltage required to reach the danger current.

Under normal operating conditions, this voltage range (< 50 V) is therefore not dangerous to human beings.

Circuit breakers for direct current applications (cont.)

24 V - 48 V direct current applications

Examples of applications

Industrial applications

Monitoring of agro-food tanks with 24 V DC converters for probes and other sensors

- Isolated network:
- $I_{sc} = 20 \text{ kA}$,
- $I_n = 40 \text{ A}$.

Solution

iC60H 2P 40 A + 24 V converters

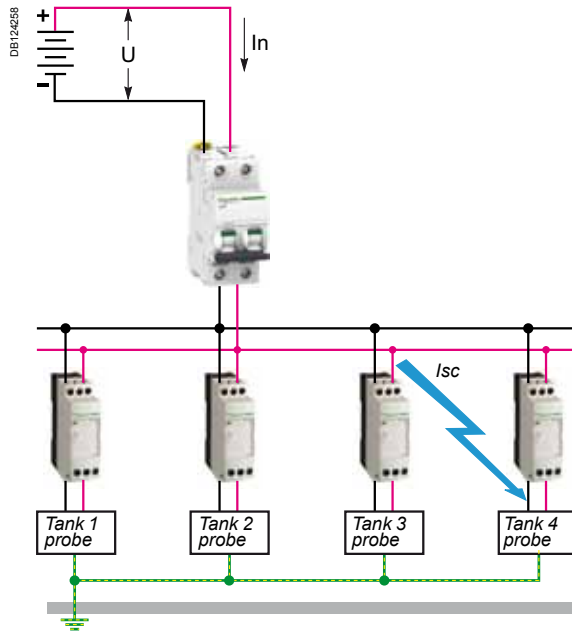

Control of industrial process measurement by 12/24/48 V DC control

- Isolated network:
- $I_{sc} = 20 \text{ kA}$,
- $I_n = 40 \text{ A}$.

Solution

iC60H 2P 40 A + DC solid-state relays

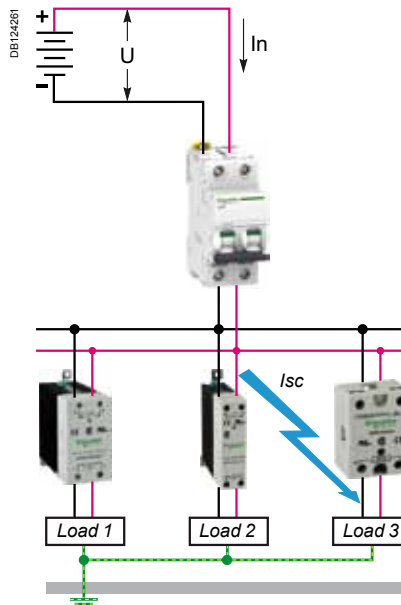

Circuit breakers for direct current applications (cont.)

24 V - 48 V direct current applications

24 V DC generator power supply protection

- Earthed network:
- $I_{sc} = 10 \text{ kA} / I_n = 63 \text{ A}$,
- $I_{sc} = 10 \text{ kA} / I_n = 20 \text{ A}$.

Solution

iC60H 2P 63 A + iC60N 2P 20 A + DC loads

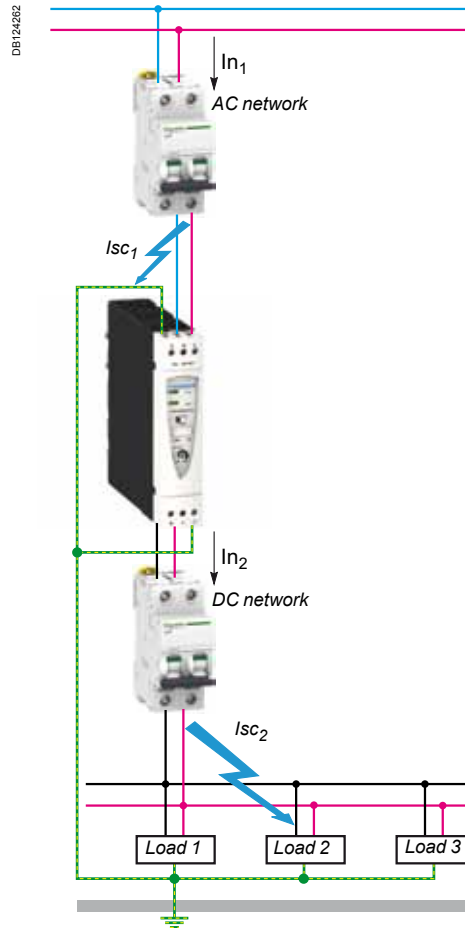

Circuit breakers for direct current applications (cont.)

24 V - 48 V direct current applications

Tertiary applications

Control and monitoring of the 48 V DC emergency lighting distribution for a shopping centre

■ Mid-point of the network:

□ $I_{sc} = 20 \text{ kA}$,

□ $I_n = 125 \text{ A}$.

Solution

NG125H 3P 125 A + power contactors

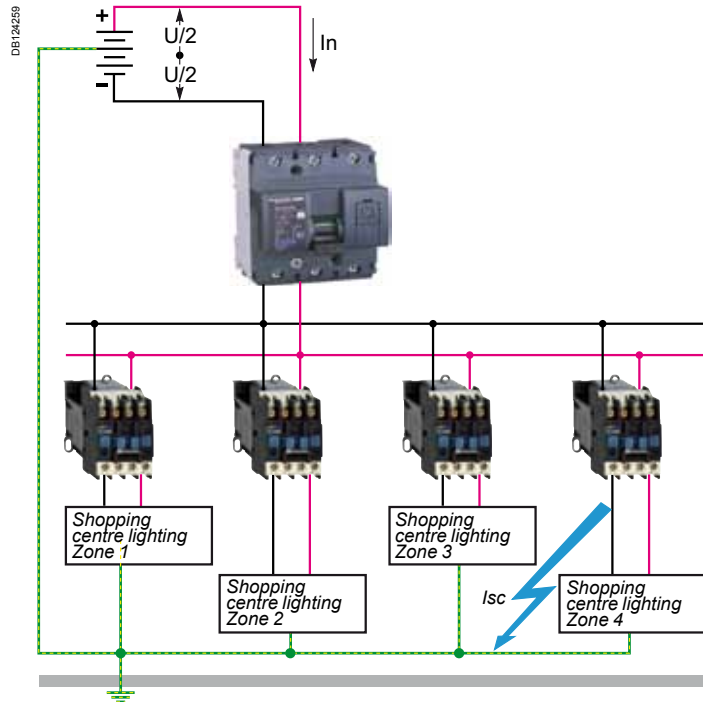

Circuit breakers for direct current applications (cont.)

24 V - 48 V direct current applications

Power supply protection by 24 V DC direct current generator

- Earthed network:
- $I_{sc1} = 10 \text{ kA} / I_n = 40 \text{ A}$,
- $I_{sc2} = 10 \text{ kA} / I_n = 2/4/6 \text{ A}$.

Solution

iC60H 2P 40 A + iC60H 2P 2/4/6 A + PLC inputs + DC loads

The Phaseo network failure solution provides the installation (or part thereof) with a 24 V DC power supply in the event of a mains voltage failure:

- throughout the mains failure, to ensure the continuity of service of the installation.
- during a limited time to allow:
 - data to be backed up,
 - actuators to be put in the fallback position,
 - a generating set to be started up,
 - the operating systems to be shut down,
 - remote supervision data to be transmitted.

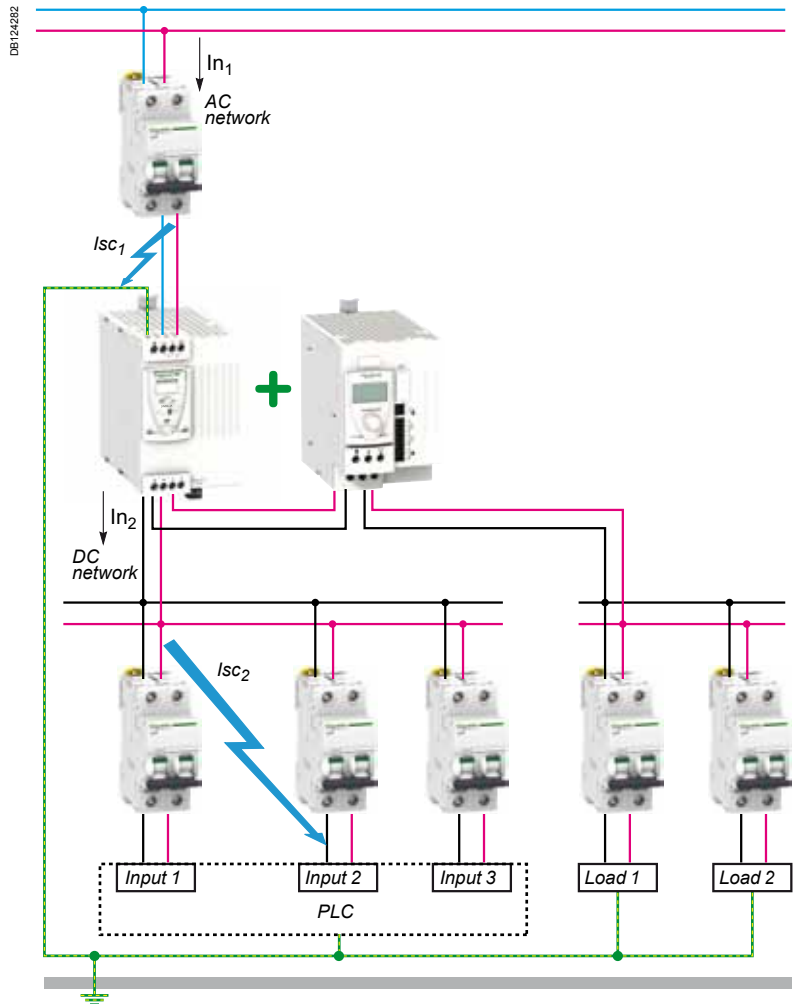

Compatibility of 50/60 Hz equipment with a 400 Hz network

The performance of products designed for domestic frequencies of 50/60 Hz is impacted by the specific properties of networks of 400 Hz frequency.

Phenomena due to the increased frequency influence the behaviour of the copper components of transformers, cables and protective equipment.

Some types of equipment designed for 50/60 Hz networks may not be suitable. You should check whether or not a product is compatible and also apply any correction factors given by the manufacturer.

Circuit breakers

Depending on the technologies used, modular circuit breakers designed for 50/60 Hz can be used at 400 Hz.

To choose the performance of a modular circuit breaker:

- do not take any thermal derating into account (In at 400 Hz is equivalent to In at 50 Hz).
- increase the magnetic tripping threshold, according to the table below.
- check that the short-circuit current on the installation is less than the breaking capacity of the circuit breaker. The breaking capacity of the circuit breakers at a frequency of 400 Hz is the same as at frequencies of 50/60 Hz. This characteristic is generally complied with, due to the fact that the short-circuit current of a 400 Hz generator is relatively low. In most cases, the generator I_{sc} does not exceed four times the rated current.

Circuit breaker	Curve	Magnetic trip thresholds		
		50 Hz	400 Hz	Tolerance
iDPN, DPN	B	4 I _n	6 I _n	± 20 %
	C	8 I _n	12 I _n	
	D	12 I _n	18 I _n	
iC60	B	4 I _n	5.6 I _n	
	C	8 I _n	11.2 I _n	
	D	12 I _n	16.8 I _n	
C60	B	4 I _n	5.1 I _n	
	C	8.5 I _n	10.9 I _n	
	D	12 I _n	15.4 I _n	
C120	The NG125 and C120 circuit breakers are not suitable for networks of 400 Hz frequency. Refer to the Compact NSX offer.			
NG125				

Earth leakage protection devices

The residual current device trip thresholds designed for 50/60 Hz increase with the frequency, but since the human body is less sensitive to the passage of a current at 400 Hz, protection is still ensured for the users.

According to the IEC 60479-2 standard, at 400 Hz the ventricular fibrillation threshold is higher by a ratio of 6 (which means that the physiological effect of a 180 mA current at 400 Hz will be the same as that of a 30 mA current at 50/60 Hz).

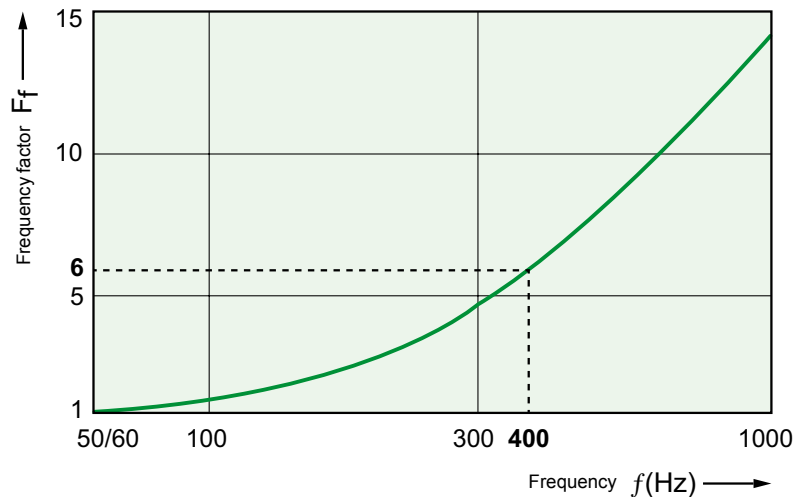

Variations in the ventricular fibrillation threshold for shock durations exceeding the period of cardiac cycle (as per IEC 60479-2).

Compatibility of residual current devices at 400 Hz:

Depending on the type and the technology employed, a residual current device designed for a frequency of 50/60 Hz will or will not be capable of ensuring protection for users in accordance with the requirements of the standard.

Type of protection and type of equipment	Use possible on network of 400 Hz frequency	Limit	
A type	Not compatible	Trip threshold exceeding the limit given by the curve	
AC type	Not recommended	Excessive sensitivity with risk of unwanted tripping (poor guarantee of continuity of service)	
Si type	iID	YES	
	Vigi iC60	Not compatible	Trip threshold exceeding the limit given by the curve
	DPN Vigi, Vigi DPN	YES	

Note: The choice of an iID residual current circuit breaker ensures protection for users at 400 Hz while ensuring good continuity of service.

At 400 Hz, the test function of residual current devices designed for 50/60 Hz is not operational due to the increase in the trip threshold.

Auxiliary function

Voltmetric releases

If a circuit breaker needs to be provided with a voltmetric release whose control circuit is powered by the 400 Hz network, it is necessary to use a release auxiliary of appropriate characteristics for 400 Hz networks:

Type	Voltage	Cat. no.
Undervoltage release iMN	115 V AC - 400 Hz	A9A26959

Part number	A	B	C
SEA9AN2	200	300	117
SEA9AN6	273	300	117
SEA9AN10, SEA9AN26DS	345	300	117
SEA9SNI4, SEA9AN26SL, SEA9AN66DS, SEA9AN616MS, SEA9ANI08MS	417	300	117
SEA9ANI8, SEA9AN6S6, SEA9AN510SL, SEA9AN96SL, SEA9ANI06DS, SEA9AN624MS, SEA9ANI016MS, SEA9ANI48MS	489	300	117
SEA9AN27, SEA9ANI0S10, SEA9ANI432MS	417	530	117

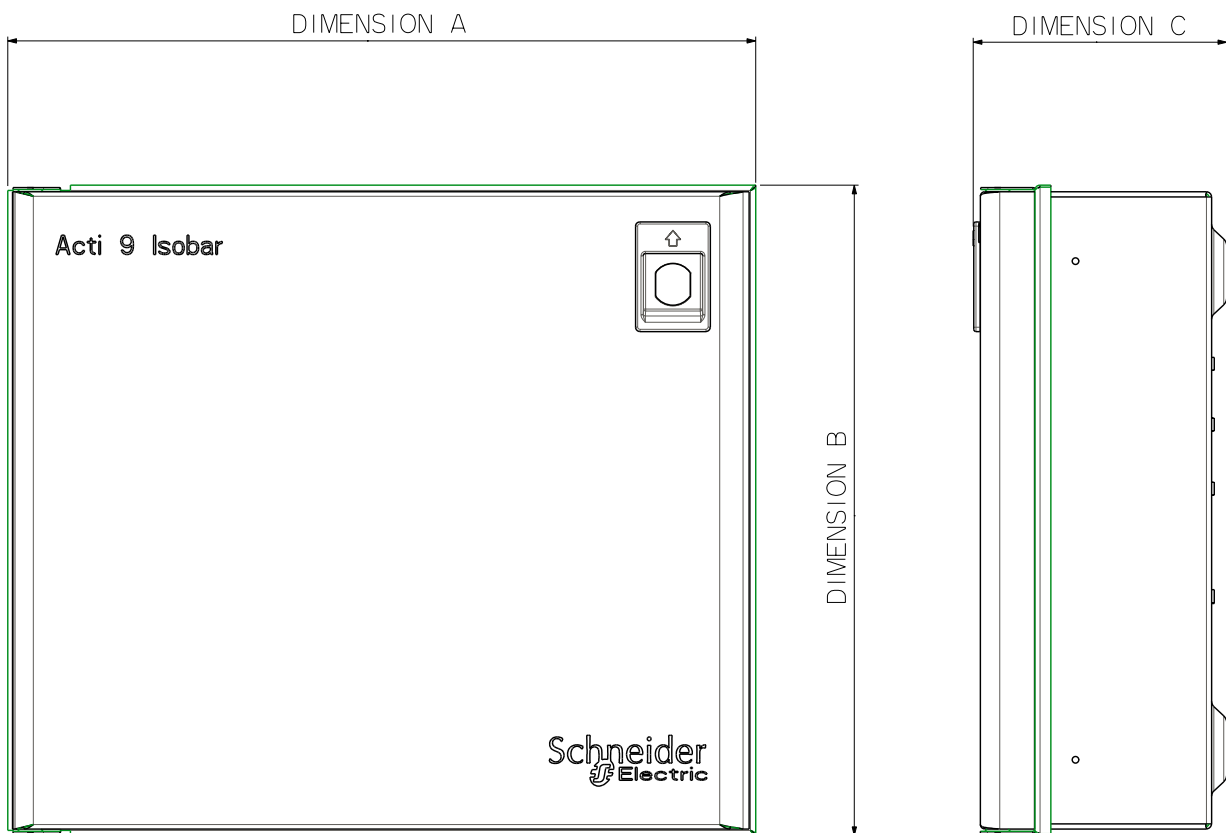

Key hole slot dimensions

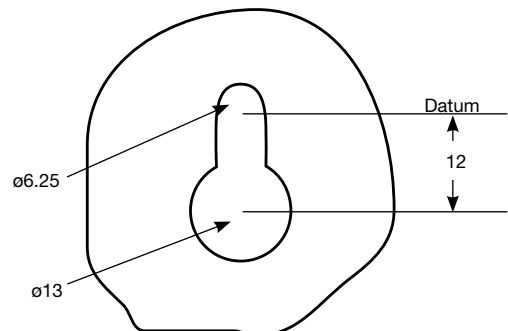

Dimensions (mm)

Distribution boards B type

Part number	A	B
SEA9BN4,SEA9BN6	484	386
SEA9BN8	538	440
SEA9BN12	700	602
SEA9BN16, MGBN18	862	710
SEA9BN24	1024	872
SEA9BN split metering	1294	1192

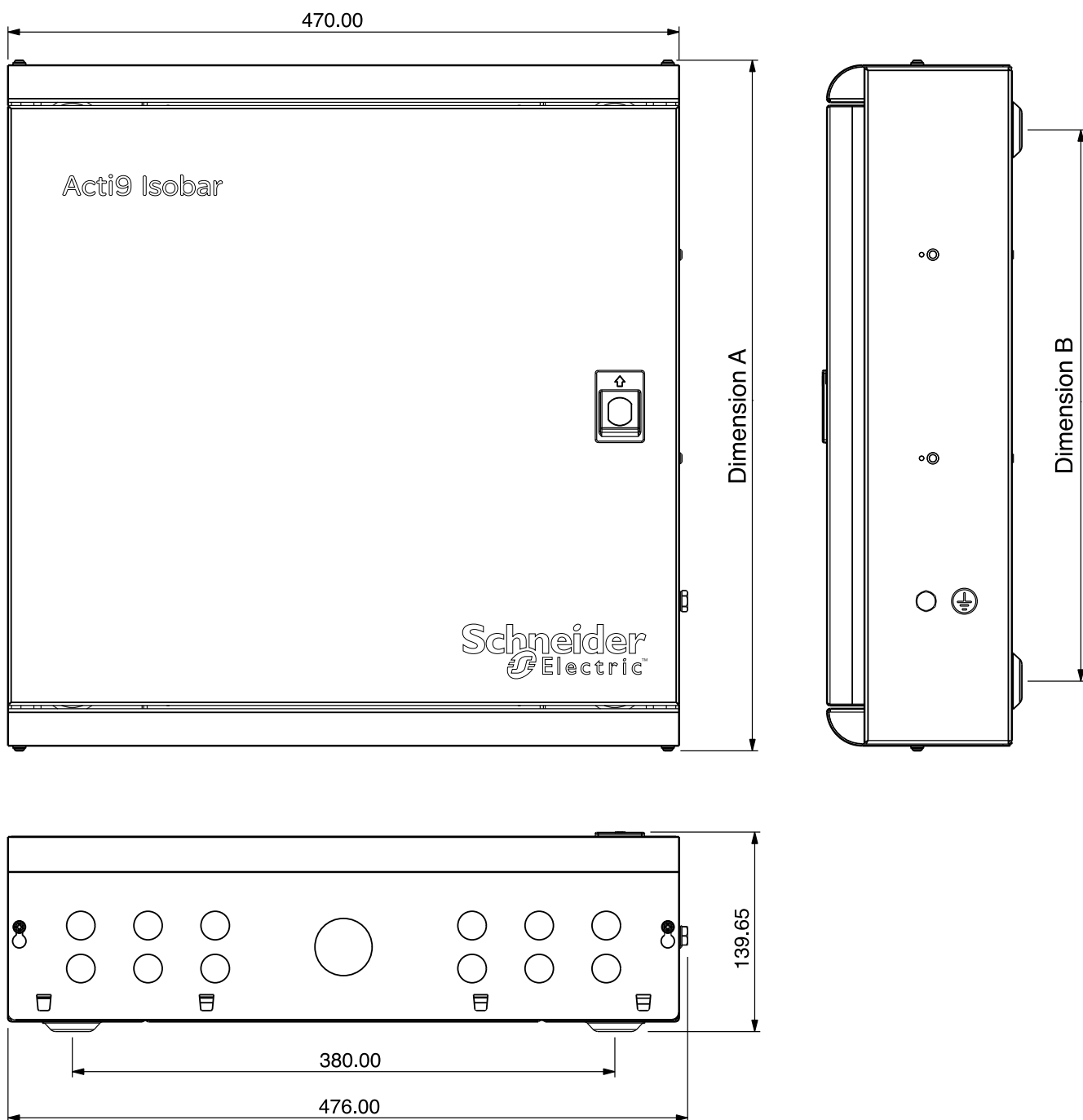

Dimensions (mm)

Heavy duty distribution board (100A) IP55 weatherproof

Part number	Number of	Dimensions (mm)		
		Height	Width	Depth
SEA9BN6HDGK/G-R	6	650	600	290*
SEA9BN8HDGK/G-R	8	650	600	290*
SEA9BN12HDGK/G-R	12	850	600	290*
SEA9BN16HDGK/G-R	16	850	600	290*

* Denotes the maximum depth dimensions with key fitted.

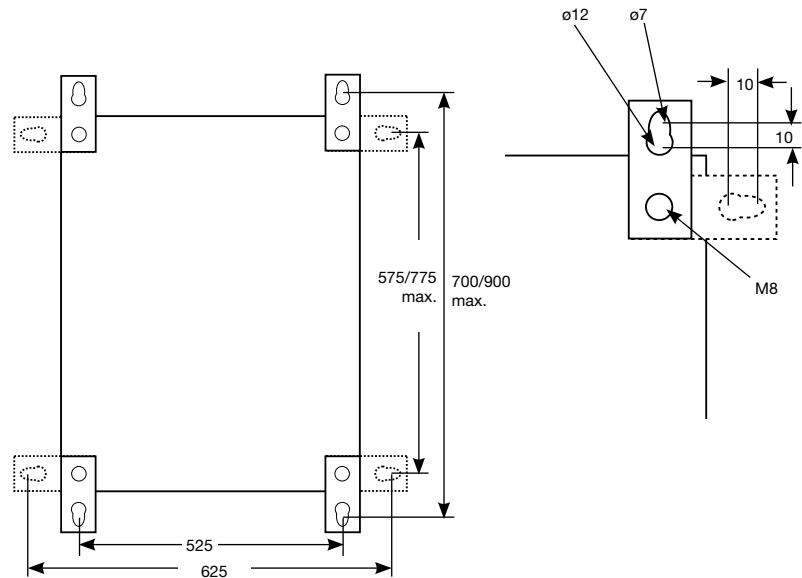

B board extension box enclosures

Part number	A
SEA9BNEXN	124
SEA9BNEX034N	140
SEA9BNKWH	124
SEA9BNEXA15N	140
SEA9BN100CCI	140
SEA9BNDSI	124

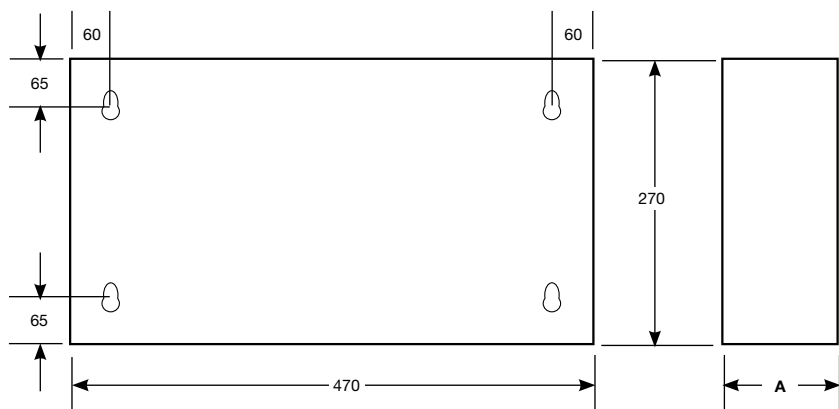

Weight (g)

Circuit-breaker	
Type	iC60H
1P	125
2P	250
3P	375
4P	500

Dimensions (mm)

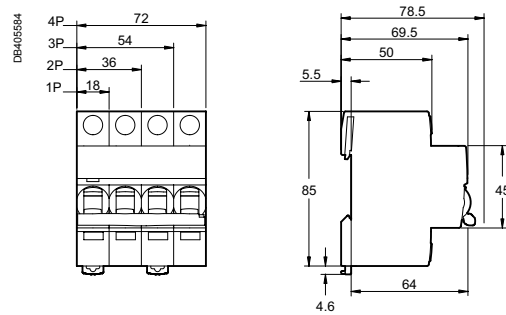

Weight (g)

Add-on residual current devices

Type	Vigi iC60
2P	165
4P	245

Dimensions (mm)

Vigi iC60 25 A

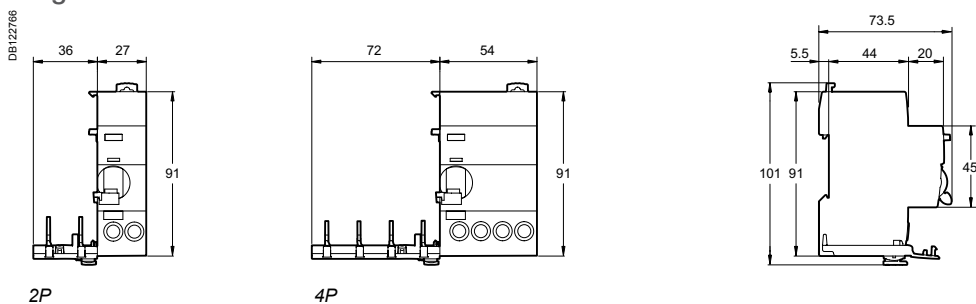

Vigi iC60 40 and 63 A

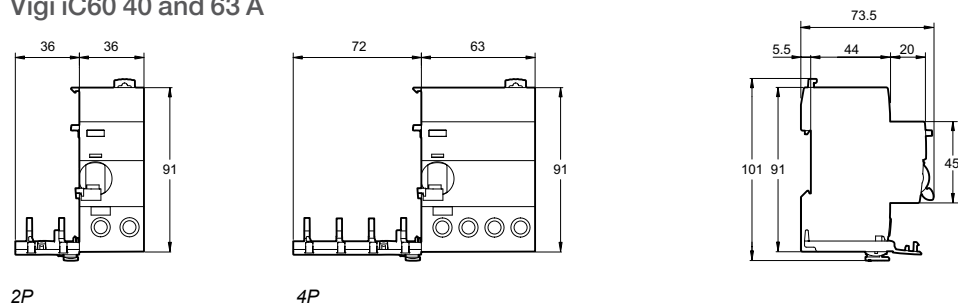

Weight (g)

iC60 RCBO	
iC60H RCBO	205

Dimensions (mm)

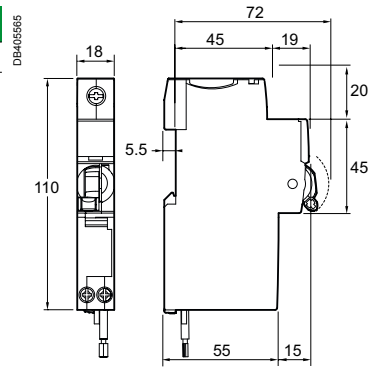

iC60N RCBO, iC60H RCBO

Technical data

Weight (g)

Electrical auxiliaries

Type	Weight (g)
iMN	69
iMNs	72
iMNx	79
iMSU	68
iMX	64
iMX+OF	68
iOF	32
iSD	33
iOF/SD+OF	43
iOF+SD24	25

Dimensions (mm)

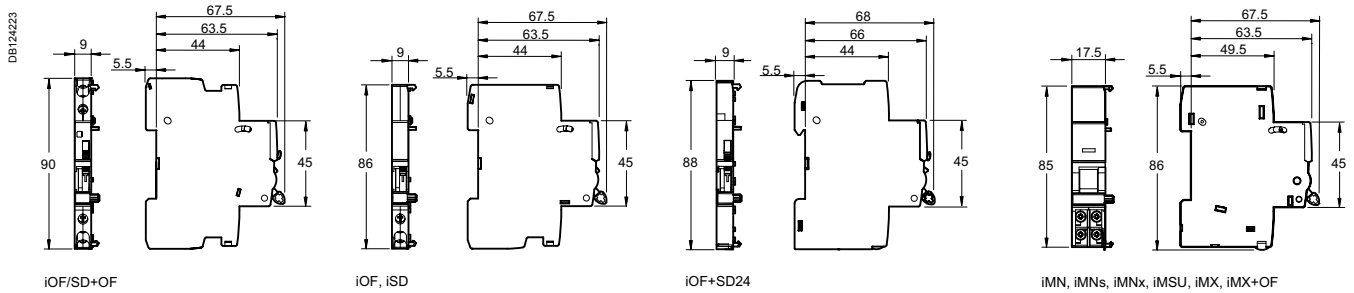

Dimensions (mm)

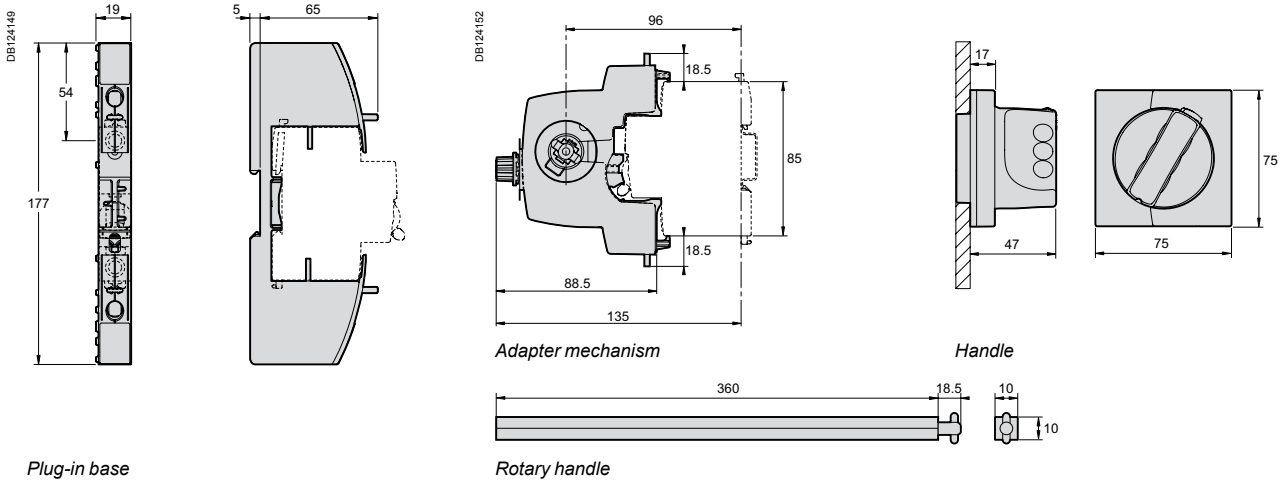

Plug-in base

Adapter mechanism

Handle

Rotary handle

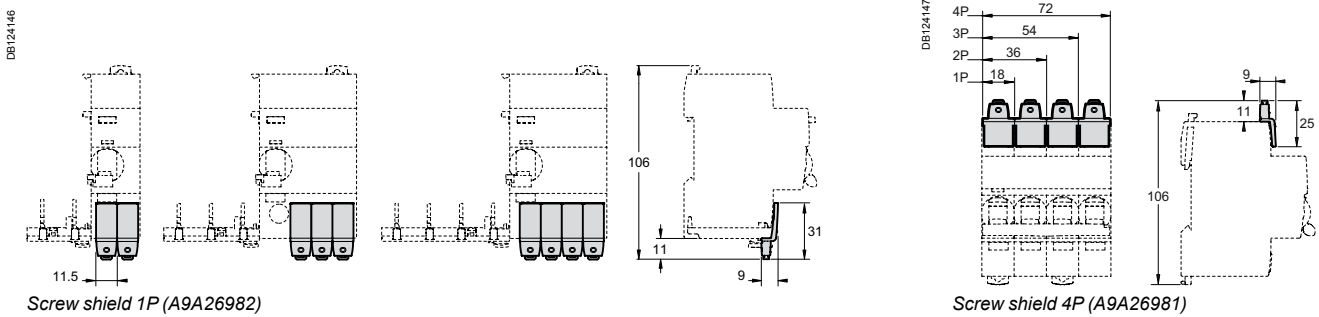

Screw shield 1P (A9A26982)

Screw shield 4P (A9A26981)

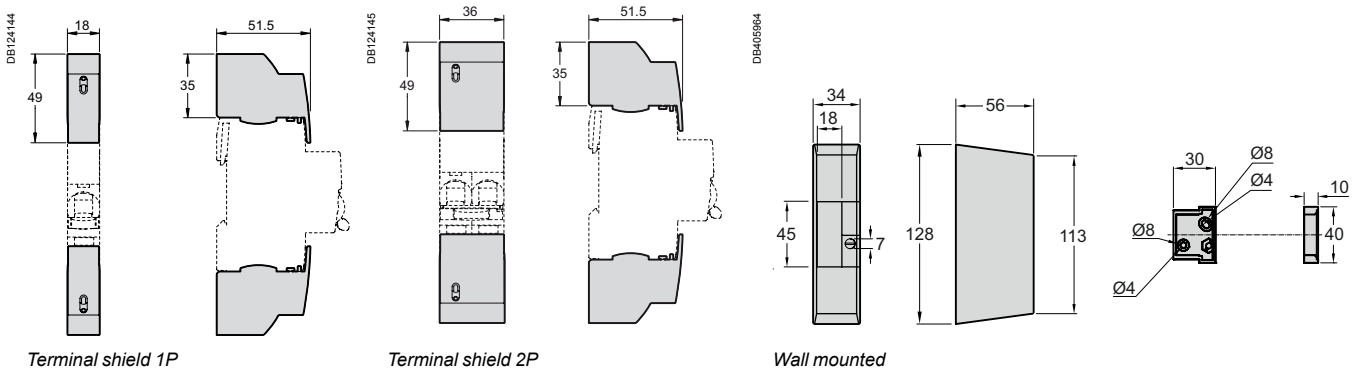

Terminal shield 1P

Terminal shield 2P

Wall mounted

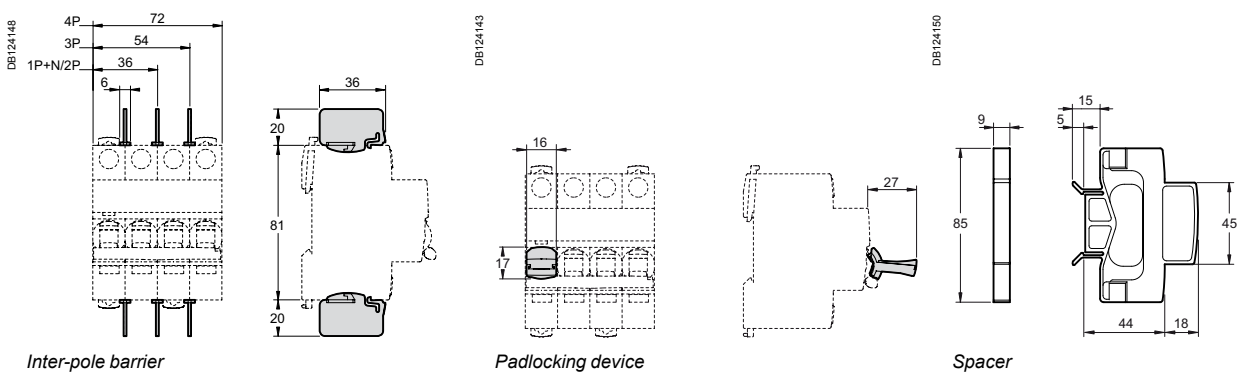

Inter-pole barrier

Padlocking device

Spacer

Rotary handle installation

Dimensions (mm)

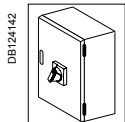

iC60	Z (mm)
2P	25.3
2P + Vigi	25.3
3P	25.3
3P + Vigi	43
4P	43
4P + Vigi	43

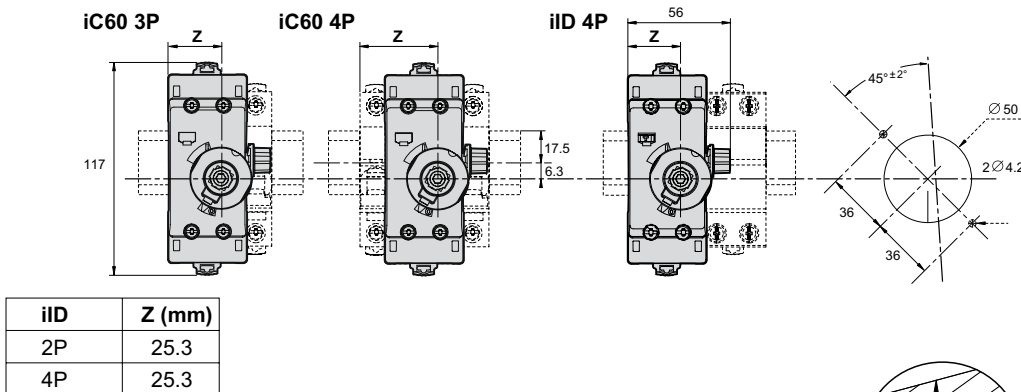

iID	Z (mm)
2P	25.3
4P	25.3

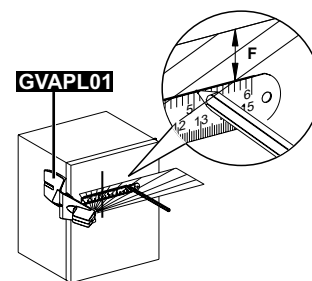
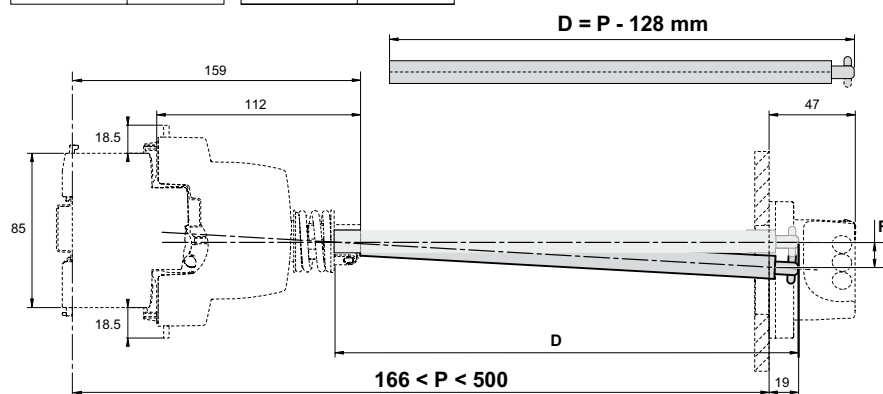

P (mm)	F (mm)
300	5
500	11

Rotary handle: front mounted control

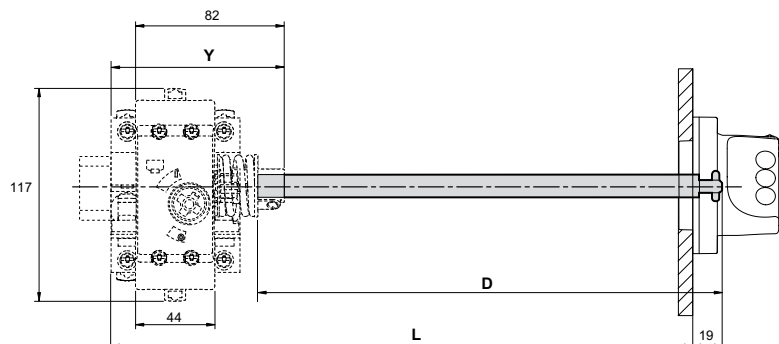
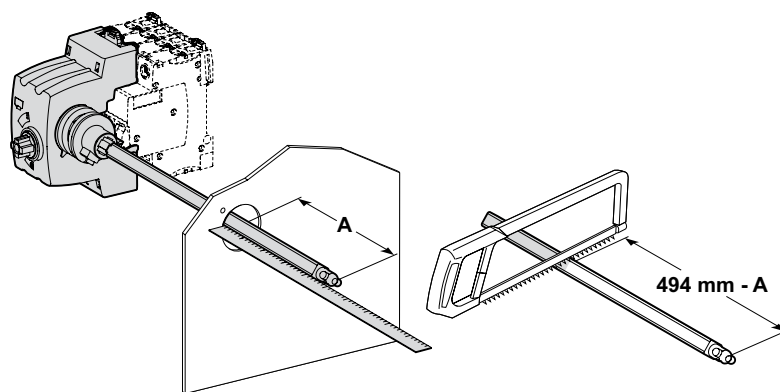
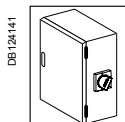

iC60	X (mm)	Y (mm)
2P	44.5	76.8
2P + Vigi	44.5	76.8
3P	44.5	76.8
3P + Vigi	62	94.5
4P	62	94.5
4P + Vigi	62	94.5

iID/iSW-NA	X (mm)	Y (mm)
2P	44.5	76.8
4P	44.5	76.8



Rotary handle: side mounted control

iID residual current circuit breakers (AC, A, *SI* types) (cont.)

Weight (g)

Residual current circuit breakers	
Type	iID
2P	210
4P	370

Dimensions (mm)

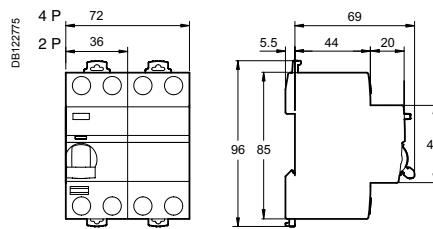



UK contact details -

0870 608 8 608

Fax 0870 608 8 606

Ireland contact details -

01 601 2200

Fax 01 601 2201

As the global specialist in energy management with operations in more than 100 countries, Schneider Electric offers integrated solutions across multiple market segments, including leadership positions in energy and infrastructure, industrial processes, building automation, and data centres/networks, as well as a broad presence in residential applications.

Schneider Electric is dedicated to making individuals' and organisations' energy safe, reliable, efficient, productive and green from Power Plant to Plug™.

We are changing our brand names and becoming one Schneider Electric. You'll get the same great quality products, but from one name you can remember and trust. This provides you and your customers with the reassurance associated with Schneider Electric.

Some of our market leading brands have already become Schneider Electric including **Merlin Gerin, Telemecanique, Square D, GET, Mita, Sarel, Himel, Thorsman, Tower** and **TAC**.

Working as one Schneider Electric makes it clearer that our ranges are highly compatible for integrated solutions.

Schneider Electric Ltd

United Kingdom
Stafford Park 5,
Telford
Shropshire
TF3 3BL
Tel: 0870 608 8 608
Fax: 0870 608 8 606
www.schneider-electric.com/uk

Ireland
Head office,
Block a
Maynooth Business Campus
Maynooth, Co. Kildare
Tel: (01) 601 2200
Fax: (01) 601 2201
www.schneider-electric.com/ie

Schneider Electric Limited is a company registered in England and Wales.
Registered number: 1407228. Registered office: Stafford Park 5, Telford, Shropshire TF3 3BL.

© 2013 Schneider Electric. All Rights Reserved. Schneider Electric, Active Energy Management, Compact, EcoStruxure, ION Enterprise, iRIO, Make the most of your energy, Masterpact, Micrologic, Power Plant To Plug, Modbus, and PowerLogic are owned by Schneider Electric Industries SAS, or its affiliated companies in the United States and other countries.

As standards, specifications and designs change from time to time, please ask for confirmation of the information given in this publication.

member of

